



# NEW HOLLAND CX5000 & CX6000

CX5080 | CX5090 | CX6080 | CX6090



# NEW CX5000 - CX6000. ALL CROPS, ALL FARMS.



## EXCELLENT CAPACITY

New Holland CX5000 and CX6000 combines deliver outstanding field performance. The advanced threshing design and cleaning mechanism provides a superior throughput allowing impressive forward speeds and daily output.



## BEST-IN-CLASS VERSATILITY

Crop-To-Crop flexibility has never been better thanks to New Holland's advanced concave design furthermore, an easy to use choice of crop-specific settings fine tune a CX combine for optimum performance in any crop or crop condition. A wide choice of grain headers and row crop attachments ensure maximum combine versatility.

## TOP LEVEL SHARED SOLUTIONS

The styling of the New Holland CX5000 and CX6000 combines bear a strong resemblance to the New Holland flagship combine range with which they share high output levels and outstanding performance. Professional users enjoy operating a harvester that is built for the years to come, thanks to the advanced technology and a high degree of automation.





### GREAT HARVEST QUALITY

A clean, un-damaged grain sample and straw quality in line with customer requirements are guaranteed by effortlessly fine tuning the combine's many settings.



### EASE OF OPERATION

Simple automation of all basic combine functions adds to the operator's peace of mind. The overall comfort of the Discovery™ III cab enhances operator alertness while reducing the need for excessive concentration during the longest working days.



Basic models		<b>CX5080</b>	<b>CX5090</b>	<b>CX6080</b>	<b>CX6090</b>
Grain header width	(m)	4.00 - 7.32	4.57 - 7.32	4.57 - 9.14	5.18 - 9.14
Engine power @ 2100rpm	[kW/hp(CV)]	175/238	200/272	200/272	220/300
Max. engine power @ 2000rpm	[kW/hp(CV)]	190/258	220/300	220/300	245/333
Drum width / diameter	(m)	1.3 / 0.60	1.3 / 0.60	1.56 / 0.60	1.56 / 0.60
Number of strawwalkers		5	5	6	6
Grain tank capacity / Hillside version	(l)	7300	8300 / 7300	8300	9300

# A COMBINE FOR EVERY FIELD

## MATCHING YOUR OPERATION

There is always a CX model that fits your operation. There are two CX5000 models with five straw walkers and two CX6000 models with six straw walkers. All feature a 60cm drum diameter and can be specified with 2-drum or 4-drum threshing technology. Power is supplied by Tier 4A compliant common rail engines offering maximum power of between 258hp(CV) and 333hp(CV).

The standard Smart Sieve™ system eliminates the effect of side slopes of up to 25% on both sides and the standard Opti-Fan™ system adjusts fan speed in line with the fore-aft inclination of the combine.

High-Capacity and Extra-Capacity headers of up to 9.00m and Varifeed™ grain headers up to 7.24m are available as well as five, six and eight-row maize headers.



## “LATERALE” VERSION MAINTAINS CAPACITY ON STEEP SLOPES

For sustained performance in hilly conditions, CX5090 and CX6090 models are available in a “Laterale” version. A simple and robust automatic levelling system provides a transverse slope correction of up to 18% both sides. An even grainpan distribution for optimum cleaning efficiency and superb gradability and traction ensure genuine CX performance during long working days.

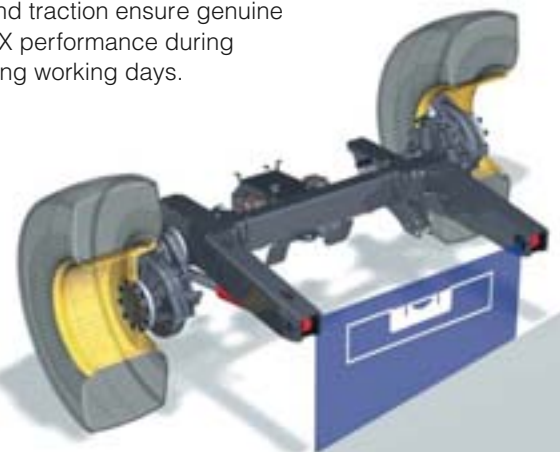

LATERALE MODELS		CX5090	CX6090
Engine power @ 2100rpm	[kW/hp(CV)]	200/272	220/300
Max. engine power @ 2000rpm	[kW/hp(CV)]	220/300	245/333
Correction across the slope	(%)	18	18
Number of strawwalkers		5	6
Grain tank capacity	(l)	8300	9300



### HILLSIDE HARVESTING, THE RIGHT WAY

For a combine operation in severe hillside conditions New Holland offers the Model CX5090 Hillside. Efficient operation of the separation and cleaning systems is ensured by two independent hydraulic systems: one for lateral slope correction and one for levelling the longitudinal axis. Safety and field efficiency are increased as the traction wheels remain vertical at all times. A powerful engine producing a maximum power of 300hp(CV), a heavy-duty hydrostatic transmission and the large disc brakes ensure optimum performance and safety in the field. Hillside versions are also available in a narrow version with a maximum overall width of 3.5m.

HILLSIDE VERSIONS		Across the slope	Uphill	Downhill
<b>Degree of correction:</b>	%	<b>38</b>	<b>30</b>	<b>10</b>

## A PERFECT START

### HIGH-CAPACITY GRAIN HEADERS KEEP THE CX GOING

A smooth crop flow from the very beginning: the large diameter reel, with easy reel adjustments, the aggressive knife action and the retractable fingers over the full intake auger width, ensure consistent crop feeding right from the start. No valuable time is wasted with the quick header coupling system and the trouble-free clearing of blockages.



#### SAVING VALUABLE SEED

Even when harvested at the optimum stage of maturity, the tangled stems and pods of rapeseed will inevitably incur shatter loss. A purposely developed vertical knife prevents the aggressive pulling apart of the crop and reduces pod shatter and seed loss to a minimum.

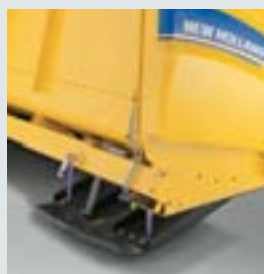

#### OPERATOR PEACE OF MIND

Automatic Header Height Control allows a choice between stubble height control or automatic pressure compensation and ensures correct header behaviour in normal working conditions. The Lateralfloat system takes care of correct transversal header positioning in uneven fields and for increased operator convenience, with the Autofloat™ system, this is operated automatically.



### VARIFEED™ GRAIN HEADERS ADAPT TO THE CROP

To work with the optimum header configuration in any particular crop, the knife position on the Varifeed™ grain header is adjustable. The for-e-aft adjustment of 500mm allows ideal knife positioning and ensures top cutting efficiency and correct feeding whatever the circumstances. This electro-hydraulic adjustment is made from the cab and the header bottom is closed in all knife positions.

### HEAVY CEREAL CROPS AND LONG STRAW MAY REQUIRE SPECIAL ATTENTION

To better cope with high crop volumes and long straw crops, the forward knife position of the Extra-Capacity grain header creates a larger feeding area. For added reliability and performance, the reel is driven hydraulically.

Grain headers		CX5080	CX5090	CX6080	CX6090
Cutting width High-Capacity grain header**	(m)	4.00 - 7.32	4.57 - 7.32**	4.57 - 9.14	4.57 - 9.14
Cutting width Extra-Capacity grain header**	(m)	6.10 - 7.32	6.10 - 7.32**	6.10 - 9.14	6.10 - 9.14
Cutting width Varifeed™ grain header**	(m)	5.18 - 7.32	5.18 - 7.32**	5.18 - 7.32	5.18 - 7.32
Cutting width High-Capacity Hill Side grain header	(m)	–	4.57 - 6.10	–	–

\*\* Not available on Hillside version – Not available

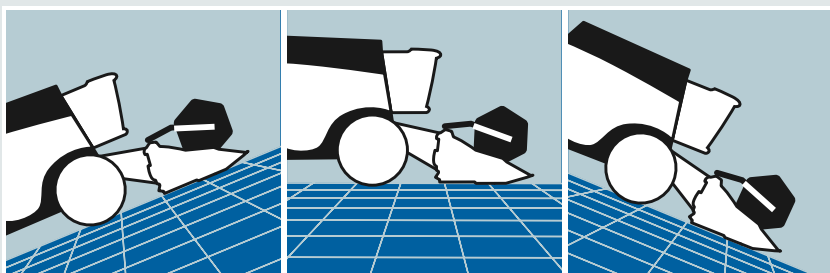

For perfect header positioning accuracy in rolling conditions, the optional Autofloat™ II system corrects the “exaggerated weight signal”. This feature avoids header bulldozing when working downhill and maintains correct stubble height when working uphill.

## A PERFECT MATCH

### MAIZE HEADER PERFORMANCE IN LINE WITH CX PRODUCTIVITY

Five, six and eight-row high performance New Holland headers are part of the offering for a professional maize operation.

Both the rigid, or where road transport is an issue, the flip-up versions are designed for top harvesting performance in varying crop conditions. The stalk rolls have 4 knives for aggressive pulling down of any size of stalk and the deck-plates are electrically adjustable from the cab, to adapt to changing stalk and cob size. Optional rotary dividers add to the smooth crop intake in fallen maize crops.



Maize headers		CX5080	CX5090	CX6080	CX6090
Flip-up maize headers	Number of rows	6	6**	6	6** - 8**
Rigid maize headers	Number of rows	5 - 6	5** - 6	6 - 8	6 - 8

\*\* Not available on Hillside version – Not available





### BEST-IN-CLASS CHOPPING

For fine chopping and superb spreading of the chopped material integrated stalk choppers can be fitted. Maximum flexibility is ensured by the individual row engagement. Users of New Holland maize headers and their integrated stalk choppers confirm that they are “the best-in-class”.

### FULLY ADAPTING TO THE MAIZE CROP

Efficient threshing of maize and beans requires a low drum rpm. The optional drum speed reducer allows working with appropriate settings, adding to the combine’s versatility.



### FIT FOR OPERATING IN ROLLING FIELDS

Operating New Holland maize headers in rolling or even hilly field conditions is no problem. When mounted on the “Laterale” models, there is a special drive-line to cope with the shifting header position.



### ROW GUIDANCE BOOSTS FIELD PERFORMANCE

Long working days demand high operator concentration. Digital sensors on the optional Automatic Row Guidance system continuously monitor the combine’s position and keep it on track for accurate harvesting. On top of reducing operator fatigue the Automatic Row Guidance system reduces cob losses.

## FOUR-DRUM THRESHING AND SEPARATION INCREASES

New Holland CX5000 and CX6000 combine models benefit from the four-drum technology: threshing drum with Opti-Thresh™ system, beater, Rotary Separator, and Straw Flow™ beater. Extremely versatile, the system can be adapted to suit a wide variety of crops and different harvesting conditions with no compromise in kernel and straw quality or throughput.

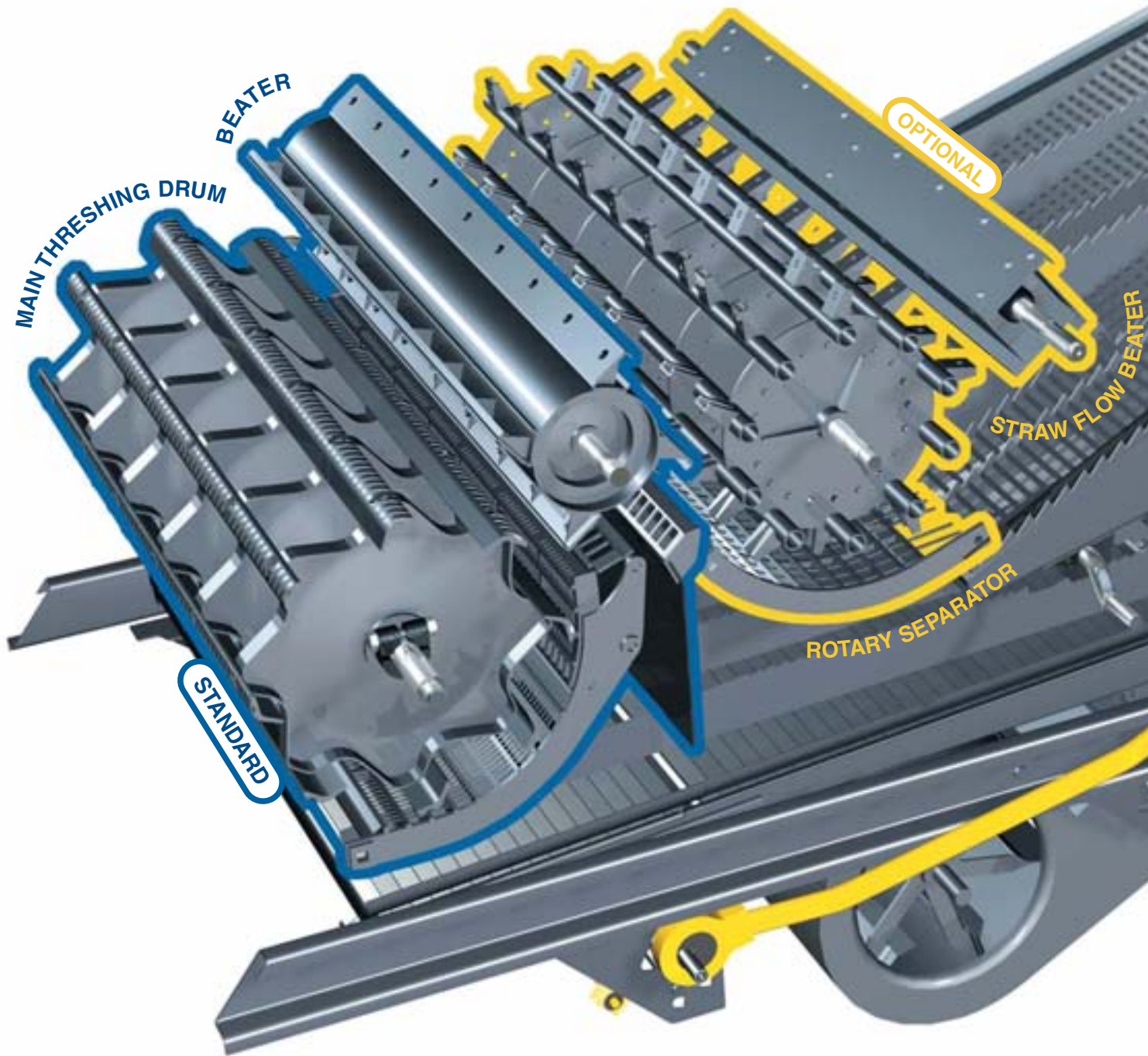

### IMPRESSIVE THRESHING PRODUCES INTACT KERNELS

The rubbing action created by the 60cm diameter drum gently but firmly releases all grain kernels from the ears in even the thickest crop layer. With a wrap angle of up to 121 degrees the concave rubbing area is just huge. Drum speed adjustment and fine concave setting are cab-controlled.

# THROUGHPUT

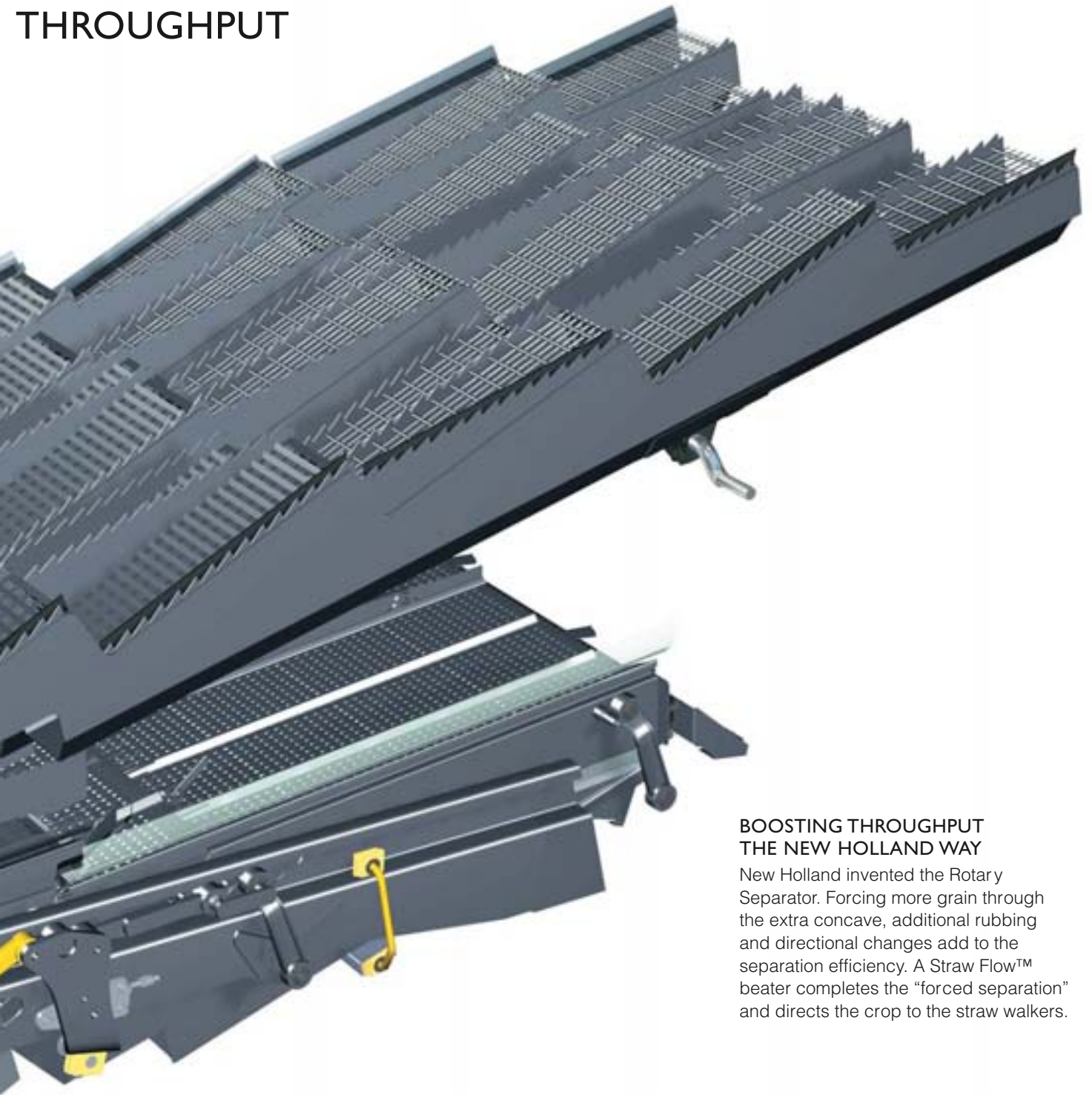

## **BOOSTING THROUGHPUT THE NEW HOLLAND WAY**

New Holland invented the Rotary Separator. Forcing more grain through the extra concave, additional rubbing and directional changes add to the separation efficiency. A Straw Flow™ beater completes the “forced separation” and directs the crop to the straw walkers.

## **STURDY EFFICIENCY**

Final separation of any grain remaining after the intense forced separation by the four-drum technology is taken care of by the straw walkers. Their closed bottom design adds strength and life-long reliability and ensures even delivery of separated grain to the grain pan when working on side slopes.

## QUICK AND EASY ADAPTATION TO ALL CROPS

Adding to their extreme versatility, New Holland CX5000 and CX6000 combine models have an ingenious package of adaptation possibilities that ensure outstanding performance in any number of crops and crop conditions. These avoid the need for compromise on grain or straw quality. The ease of adapting the machine from one crop to another is amazing.

### RUBBING ON DEMAND: THE OPTI-THRESH™ SYSTEM

Adapting to grain maturity and yield can be done with the Opti-Thresh™ system, by repositioning the rear part of the concave. When closed the concave offers a full 121 degree of wrap. When the hinged top section is moved away from the drum, the rubbing action is less aggressive and the straw quality is improved. Changing the position of the Opti-Thresh™ concave section is achieved by moving a single handle, making it more convenient to use.

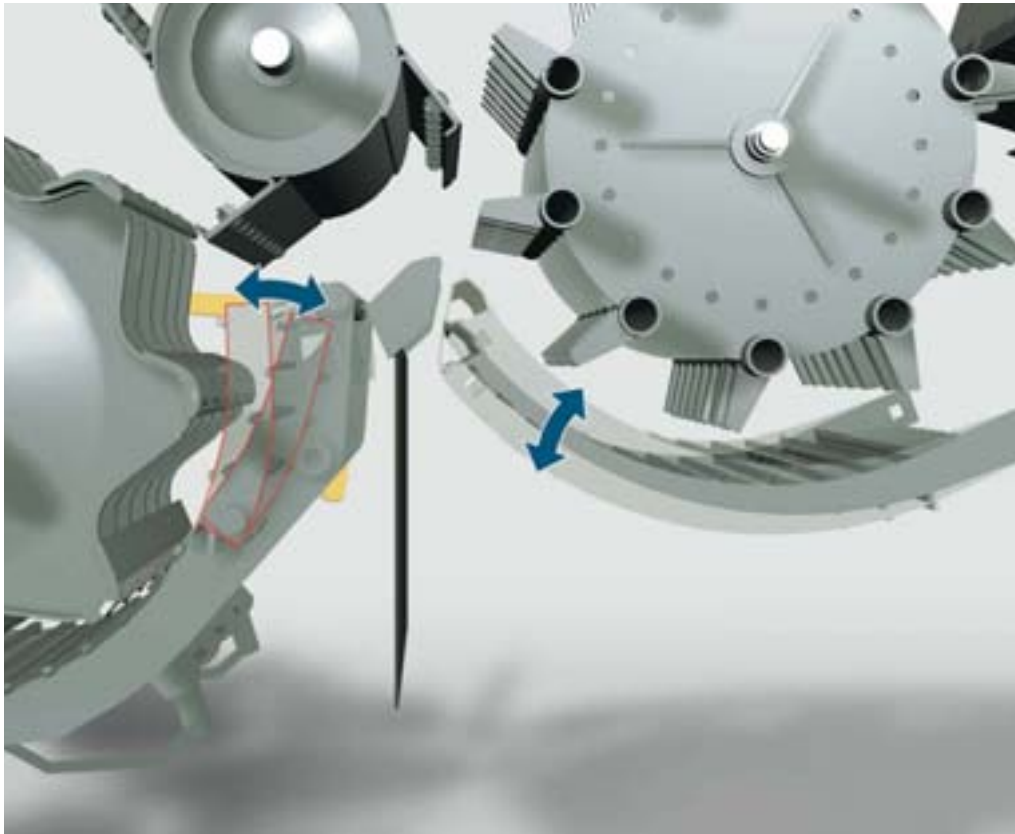

Four drum technology	CX5080	CX5090	CX6080	CX6090
Opti-Thresh™ system	●	●	●	●
Multi-Thresh™ system	○	○	○	○
Rotary Separator with Straw Flow™ beater	○	○	○	○
Full adjustability	●	●	●	●

● Standard ○ Optional

### ULTIMATE PERFORMANCE THANKS TO THE MULTI-THRESH™ SYSTEM

Different cereal varieties or varying degrees of crop moisture can be addressed thanks to the Multi-Thresh™ system with two positions of the Rotary Separator concave. This adjustment in addition to the twin Rotary Separator speed range allows crop conditions to be perfectly matched.



**OPTIONAL SECTIONAL CONCAVE:  
EASY TO MANAGE, QUICK TO CHANGE**

Reducing the rebuilding time from 6 hours to 20 minutes!  
When switching from one crop to another, without removing the straw elevator, the following concave sections can be replaced:



**Std. drum & small grain sectional concave**

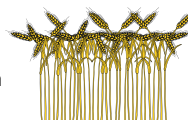

**Std. drum & Std maize sectional concave**



**Universal drum & rice sectional concave**

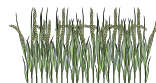

**EASY ADJUSTMENTS**

The handles for changing the position of the Opti-Thresh™ top concave section or the Multi-Thresh™ Rotary Separator concave are easily accessible on the right hand side of the combine. Also the drive belt tensioner, for changing the Rotary Separator speed, is easily accessible.

**SWITCHING FROM CEREALS TO RICE: THE UNIVERSAL DRUM**

There is no need for a complete drum replacement when changing from cereals to rice, or vice versa: the slats on the universal drum can be replaced in no time.

# A STEADY FLOW OF CLEAN GRAIN

The cleaning efficiency of the New Holland CX5000 and CX6000 combine models matches their high threshing and separation capacity. Large adjustable sieves, moving in opposite directions, and a powerful fan delivering an even distribution of air, are complemented by ingenious extra features: the pre-sieve with an extra cascading effect, the Smart Sieve™ concept that virtually eliminates side slope effects and the award-winning Opti-Fan™ system that adapts the air flow to the longitudinal slope of the combine.



## DEALING WITH SIDE-SLOPES: THE PATENTED SMART SIEVE™ SYSTEM

### NEUTRALISING THE EFFECT OF SIDE SLOPES UP TO 25% BOTH SIDES

The standard Smart Sieve™ system creates a lateral sieve movement directing the grain kernels uphill. An even layer of kernels and an even air-flow over the full width of the sieves maintain maximum cleaning efficiency.

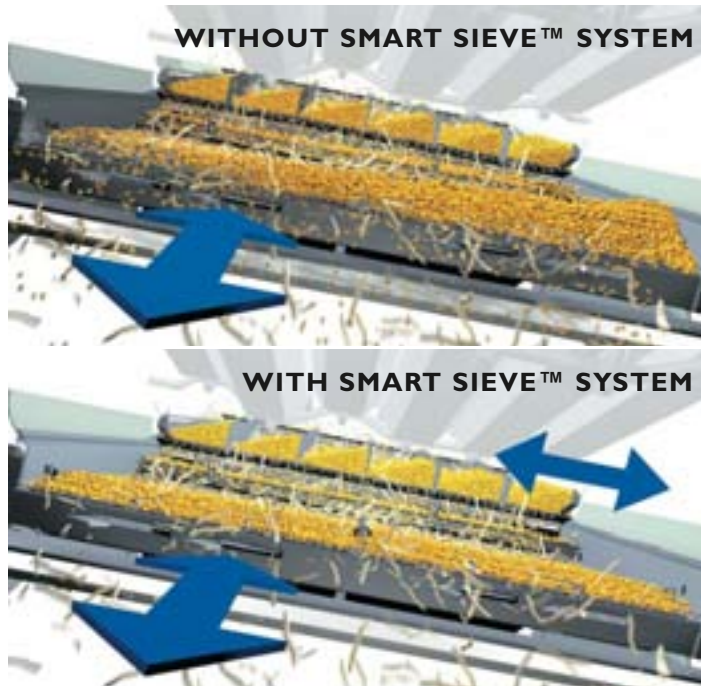

### REALLY SMART: NO RADIAL SWING ON FLAT FIELDS

The ingenious system that controls the lateral sieve movement is governed by the degree of the slope. To avoid unwanted radial swing/movement it incorporates a linkage to the sieves' pivot arm. This patented concept neutralises the radial swing and provides perfectly balanced sieve dynamics.

### EVEN SMARTER: AUTOMATIC KERNEL SIZE ADAPTATION

The lateral sieve movement is determined not only by the degree of the slope: the fan speed, which is adjusted according to the kernel size is also taken into account to determine the optimal throwing angle.

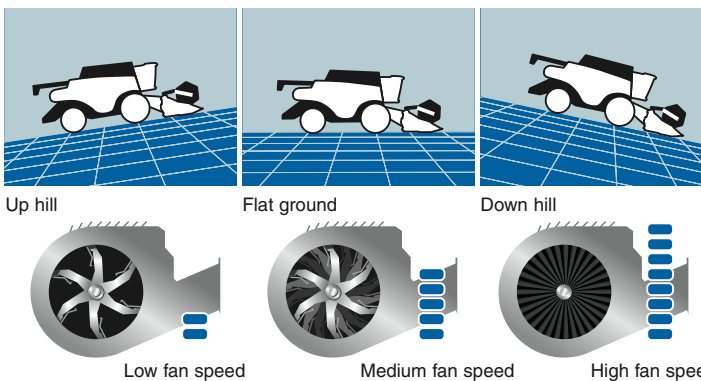

## DEALING WITH LONGITUDINAL SLOPES: THE OPTI-FAN™ SYSTEM BLOWING PRECISION

The award-winning Opti-Fan™ system consists of a simple yet very effective way of correcting fluctuations in the speed of grain flow across the cleaning shoe. Whether working up-hill or down-hill, the fan speed automatically adapts to the direction and to the degree of the slope.



### EXTRA CASCADE

Increasing the overall cleaning action, a 45cm long wind-controlled pre-sieve, with a steep slope and an additional air blast eliminates a lot of chaff and short straw even before the final cleaning is started.



### EASY GRAINPAN REMOVAL

Maintaining the aggressiveness of the grain pan steps in difficult crops like rape seed or maize may require regular cleaning. The CX combine's grain pan can be removed from the front.



### FINGERTIP CONTROL

For maximum cleaning efficiency in varying crop conditions, adjusting the sieves can be done from the cab.



# HIGH VOLUME GRAIN MANAGEMENT

Long productive days are achieved with the high grain tank capacity, matched with fast unloading speeds.

## FAST UNLOADING SAVES TIME

High unloading rates reduce time loss to the minimum. Unloading into even the highest type of grain trailer is easy with the over-top unloading system. The unobstructed view of the unloading auger allows smooth and uninterrupted harvesting while unloading.



Basic models	CX5080	CX5090	CX6080	CX6090
Grain tank capacity / Hillside version	(l) 7300	8300 / 7300	8300	9300



## SPACIOUS STORAGE, COMPLETE FILLING

Complete use of the spacious tank is ensured by the powerful bubble up filling system.



# A PROFESSIONAL WAY TO DEAL WITH CHAFF AND STRAW

High quality straw, ideal for baling is the result of the wide range of adjustment possibilities. In situations where the straw is chopped, the correct management of residue is important, especially where reduced tillage methods are practiced.



## HIGH QUALITY BALES WITH GOOD BEDDING CHARACTERISTICS

The unbroken straw found in the swath of a CX5000 or CX6000 combine is the result of the low aggressiveness of the threshing. The new straw hood has adjustable rakes which allow control of the swath width.

## THREE-WAY RESIDUE MANAGEMENT: IN THE SWATH OR ON THE STUBBLE

There is a wide choice: A twin-disc chaff spreader spreads the chaff onto the stubble before the straw hits the ground or directs it into the swath increasing the feed value of the straw to be baled. A chaff blower mixes the chaff into the straw to be chopped for distribution together with the chopped straw.

## NO ESCAPE: UNIFORM STRAW CHOPPING

The optional Dual-Chop straw chopper includes an extra rake preventing long straw from escaping. A repeated cutting of these stems ensures very uniform chopping. The high chopper speed and the remote deflector adjustment ensure powerful and uniform spreading.

# POWERFUL AND ENVIRONMENTAL: A WINNING COMBINATION

All CX5000 and CX6000 combines benefit from a high pressure common rail, Tier 4A compliant, engine developed by FPT Industrial. This is part of New Holland Agriculture's environmental promise: developing solutions that make agriculture more efficient while respecting the environment. The second part is to offer tailor-made solutions for every product, and the entire CX5000 and CX6000 range benefit from Selective Catalytic Reduction (SCR) technology. This after treatment system uses a catalyst to treat the nitrogen oxides contained in the exhaust gas, transforming them into harmless water and nitrogen, which both occur naturally in the atmosphere. As it's separate from the main engine it doesn't compromise horsepower or torque, and the cumulative result is improved engine performance and enhanced fuel efficiency.

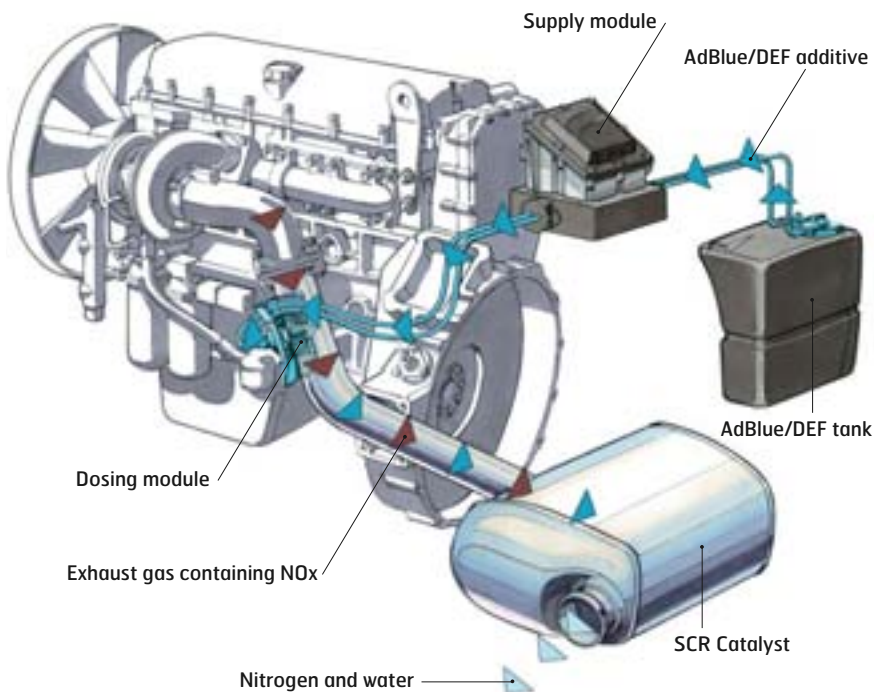

**AdBlue®**



## ADBLUE WITH NO ADDED HASSLE

AdBlue is a key component of the SCR system. It is a water and urea mix that is added to the exhaust gases to make them harmless. Available through your New Holland dealer, you will be able to store AdBlue on your farm in a container size that suits your needs. The simple system is so easy to use, just fill up your CX5000/CX6000's AdBlue tank, and when it is running low, a pop up will be displayed on the IntelliView™ III screen. The 120 litre AdBlue tank will require filling every second fill of the main diesel tank.



Basic models	CX5080	CX5090	CX6080	CX6090
Technology	Common rail	Common rail	Common rail	Common rail
Rated power [kW/hp(CV)]	175/238	200/272	200/272	220/300
Maximum power [kW/hp(CV)]	190/258	220/300	220/300	245/333
Governor	electronic	electronic	electronic	electronic



### SAVING FUEL DURING ROAD TRAVEL - NEW ROAD CRUISE MODE

For optimal fuel consumption, the engine speed reduces automatically for road transport work.



### POWER SAVING DRIVELINES

Overall reliability and low power consumption are the result of proven, direct drivelines and the 3-speed hydrostatic transmission. In line with Zedelgem tradition, all combines are constructed on an extremely robust chassis with superior material specifications.



### LARGE COOLING PACKAGE

The large radiator sections and the dust screen are easily accessible for thorough cleaning.



### UNRESTRICTED ACCESS

Large hinged panels are easily raised for servicing, allowing quick and easy access. Central grease banks further increase service accessibility and reduce service time.



## THE ABSOLUTE EXPERIENCE OF SPACE AND COMFORT

### A SPLENDID VIEW

No restrictions for a total view of the crop in front, of the header and of the stubble behind the header, thanks to the wide curved window of the Discovery™ III cab. For extended visibility up to three cameras can be installed. They add to the operator confidence when reversing, when unloading or when checking the graintank level or the chopping results.

### COMFORTABLE, SAFE AND CONVENIENT

The high comfort seat is air-suspended. An instructor seat is standard equipment just like the purpose designed cool box. The low in-cab noise levels give a relaxed working environment. To limit the total combine width when travelling or manoeuvring, the ladder can be swung in front of the traction wheel.





#### **LASER-BASED SMARTSTEER™ SYSTEM EASES DRIVING**

Precise steering in cereal crops is made easy by the optional SmartSteer™ edge guidance system. A laser scanner, mounted on the right hand platform railing, makes a distinction between the cut and uncut crop allowing for precise steering and maintaining operator alertness.



#### **READY FOR NIGHT WORK**

Maintaining high workrates when working at night is made possible with the full complement of working lights that come as standard equipment.



#### **AUTOMATIC CLIMATE CONTROL**

Air-conditioning is standard equipment. As an option it can be specified with a heating system or with the Automatic Temperature Control system, which automatically adjusts the fan speed to the degree of cooling required.

## EFFORTLESSLY MAXIMISING PERFORMANCE

Automation saves time and boosts harvester performance. The multi-function lever on the CX5000 and CX6000 combine models is the proven CommandGrip™ handle. It is built into the console on the operator's right hand side. The position of this console is adjustable to suit the operator's preference and the CommandGrip™ is a force-based propulsion handle that always comes back to its most ergonomic position irrespective of forward speed. It provides access to all major controls.

### CRUISE CONTROL AND MUCH MORE

One of the automatic functions that helps maintain high daily workrates is the Cruise Control: With a simple tap on one of the buttons on the CommandGrip™ handle, the combine resumes a set field speed.

- Reel speed and header reverser
- Emergency Stop (Header and Unloading)
- Reel position and (Varifeed™ knife and flip-up maize header + shift button)
- Unloading auger position  
Unloading auger engagement
- SmartSteer on/off OR cruise control resume
- Two speed header lift and lower system and header lateral float
- Automatic header height activation
- Shift button (Behind)
- Groundspeed unlock (Behind)
- Engine throttle
- Header width correction
- Header height memory





### JUST TOUCH THE SCREEN

Providing information on performance data, operational statistics and service data, the IntelliView™ III monitor adds to optimising the combine's performance. The wide touch screen is easy to use. One of the many time saving features available is the Automatic Crop Setting function, whereby a specific combine setting can be stored for easy recall when the same field situation pops up again.

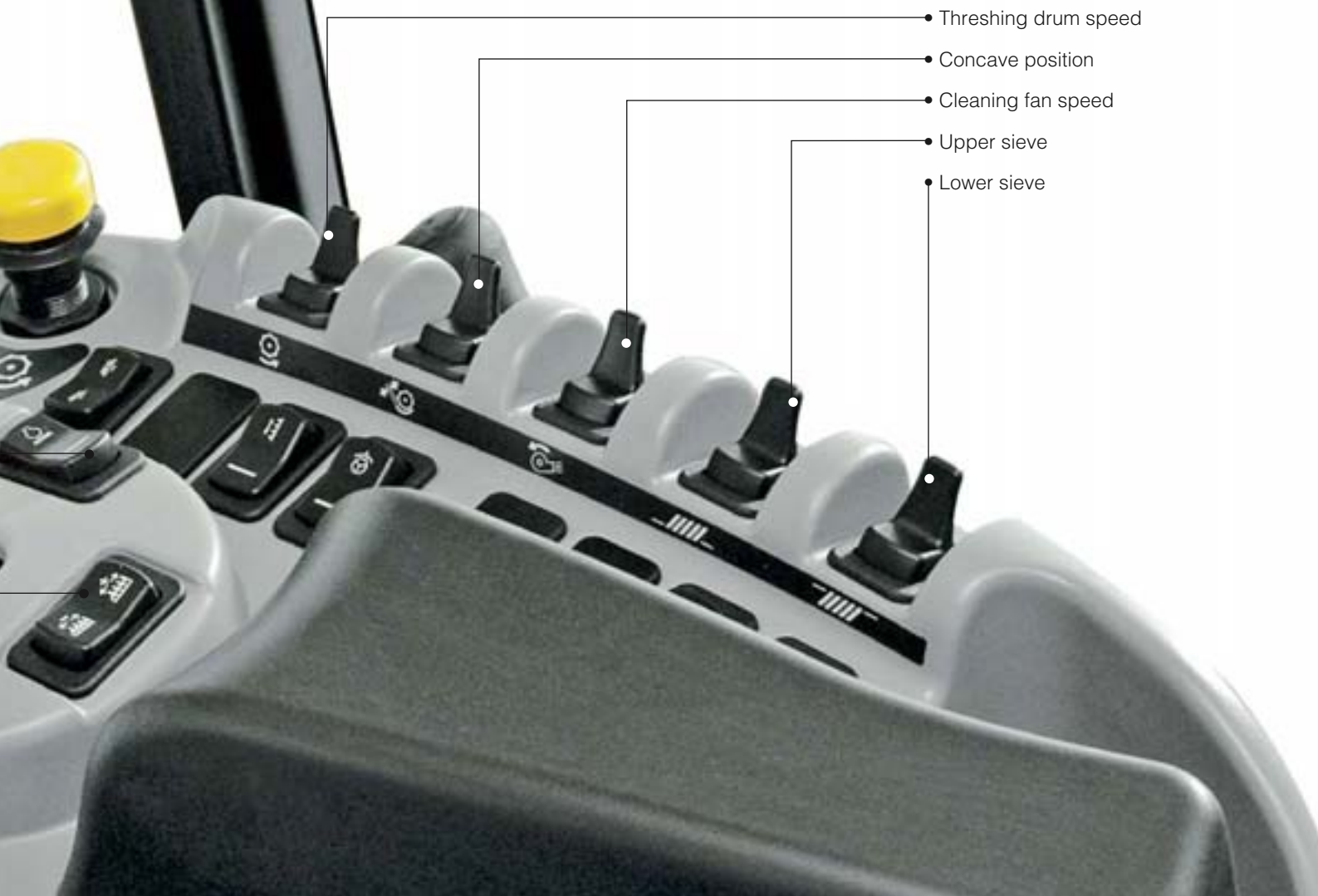

- Threshing drum speed
- Concave position
- Cleaning fan speed
- Upper sieve
- Lower sieve

# GETTING MORE FROM FERTILE GROUND

Increasing yields, or saving money through reduced inputs: precision farming is a cultivation concept that makes use of site specific crop data which in turn allows optimum treatment and seed application in the subsequent periods. CX5000 and CX6000 combine models are ready to receive the equipment that supports this way of operating.

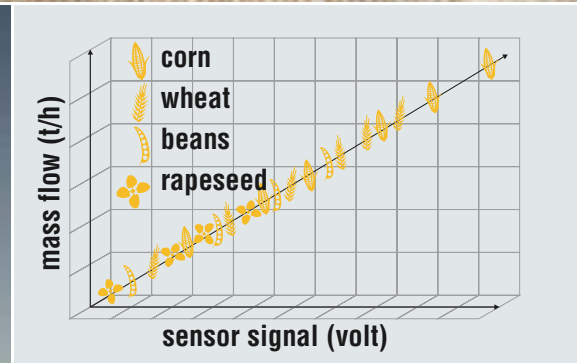
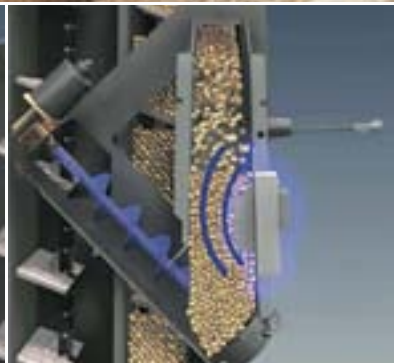

## MASS FLOW SENSOR

The exclusive, patented, high accuracy yield sensor, developed by New Holland is generally recognised as the "best in class".

## MOISTURE SENSOR

Mounted on the grain elevator, it regularly takes a sample of the harvested grain.

## NO CALIBRATION REQUIREMENT

Thanks to its design the unique New Holland yield sensor is extremely accurate whatever the crop, the variety or the moisture content of the kernel. There is no need for calibration between fields, crops or even between the cereal and maize season.

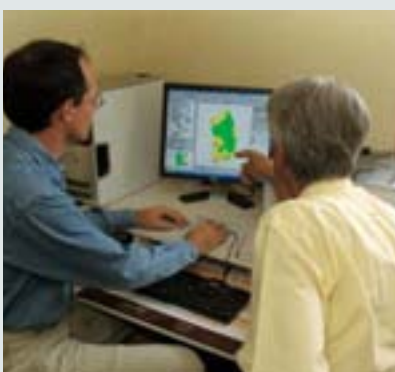

## ACCURATE MEASUREMENT OFFERS OPTIMISED INPUTS

With the addition of an optional USB Stick, the D-GPS antenna and the Precision Farming Desktop software, the CX combines offer customers valuable yield mapping information that provides key information in the move towards variable rate seed and fertilizer application.



# BEYOND THE PRODUCT



## TRAINED TO GIVE YOU THE BEST SUPPORT

Your dedicated New Holland dealer technicians receive regular training updates. These are carried out both through on-line courses as well as intensive workshop based courses. This advanced approach ensures your dealer will always have access to the skills needed to look after the latest and most advanced New Holland products.

## FINANCE TAILORED TO YOUR BUSINESS

CNH Capital, the financial services company of New Holland, is well established and respected within the agricultural sector. Advice and finance packages tailored to your specific needs are available. With CNH Capital, you have the peace of mind that comes from dealing with a finance company that specialises in agriculture.

## SERVICE PLUS LONG LASTING CONFIDENCE

Service Plus coverage from Covéa Fleet provides owners of New Holland agricultural machinery with additional cover on the expiry of the manufacturer's contractual warranty. Please ask your dealer for more details. Terms and conditions apply.



## DEALER INSTALLED ACCESSORIES

A comprehensive range of approved accessories to optimise machine performance in all conditions can be supplied and fitted by your dealer.



## WWW.NEWHOLLANDSTYLE.COM

Want to make New Holland a part of your everyday life? Browse the comprehensive selection on [www.newhollandstyle.com](http://www.newhollandstyle.com). A whole range of items are available including hard wearing work clothing and a vast selection of scale models, together with so much more. New Holland. As individual as you.

MODELS		CX5080	CX5090	CX6080	CX6090
<b>Grain header</b>					
Cutting width: High-Capacity grain header	(m)	4.00 - 7.32	4.57 - 7.32***	4.57 - 9.14	5.18 - 9.14
Extra-Capacity grain header	(m)	6.10 - 7.32	6.10 - 7.32***	6.10 - 9.14	6.10 - 9.14
Varifeed™ grain header (500mm of knife travel)	(m)	5.18 - 7.32	5.18 - 7.32***	5.18 - 7.32	5.18 - 7.32
High-Capacity Hillside grain header	(m)	–	4.57 - 6.10	–	–
Knife speed	(cuts/min.)	1150	1150	1150	1150
Spare knife and spare bolted knife sections		●	●	●	●
Feeding auger with full-width retractable fingers		●	●	●	●
Reel diameter	(m)	1,07	1,07	1,07	1,07
Electro-hydraulic reel position adjustment		●	●	●	●
Automatic reel speed synchronisation to forward speed		●	●	●	●
Hydraulic quick coupler (single location)		●	●	●	●
<b>Maize headers</b>					
Flip-up maize headers	Number of rows	6	6***	6** - 8	6** - 8**
Rigid maize headers	Number of rows	5 - 6	5** - 6	6	6
Remotely adjusted deck-plates		●	●	●	●
Integrated stalk choppers		○	○	○	○
Rotary dividers		○	○	○	○
Automatic row guidance		○	○	○	○
<b>Automatic header control systems</b>					
Stubble height control		automatic	automatic	automatic	automatic
Compensation		●	●	●	●
Autofloat™ II system		○	●	●	●
<b>Straw elevator</b>					
Number of chains		3	3	4	4
Header and elevator reverser		hydraulic	hydraulic***	hydraulic	hydraulic
Lateral flotation		○	●	●	●
<b>Discovery™ III cab</b>					
Air-suspension seat		○	○	○	○
Instructor's seat with removable coolbox (12V/220V)		●	●	●	●
IntelliView™ III monitor		●	●	●	●
CommandGrip™ handle		●	●	●	●
Up to 3 viewing camera's		○	○	○	○
Automatic crop settings		●	●	●	●
Air-conditioning		●	●	●	●
Automatic climate control		○	○	○	○
Heating		○	○	○	○
Optimum cab noise level - 77/311EEC	(dBA)	76	76	76	76
Optimum seat vibration level - EN 1032	(m/s²)	0.35	0.35	0.35	0.35
<b>New Holland Precision Land Management systems</b>					
<b>Guidance systems</b>					
SmartSteer™ automatic guidance system factory fitted		○	○	○	○
EZ-Guide 250 or 500 manual guidance system		○	○	○	○
Cruise control mode		●	●	●	●
Automatic row guidance system for maize headers		○	○	○	○
<b>Precision farming</b>					
Moisture measuring		○	○	○	○
Yield measuring and moisture measuring		○	○	○	○
Full Precision farming package including: yield measuring and moisture measuring, DGPS yield mapping, desktop software and software support service		○	○	○	○
<b>Threshing drum</b>					
Width (m)		1.3	1.3	1.56	1.56
Diameter (m)		0.6	0.6	0.6	0.6
Standard type / Universal type		● / ○	● / ○	● / ○	● / ○
Number of bars		8	8	8	8
Speed range	(rpm)	400 - 1140	400 - 1140	400 - 1140	400 - 1140
Optional drum speed reductor	(rpm)	240 - 685	240 - 685	240 - 685	240 - 685
<b>Drum concave</b>					
<b>Standard concave</b>					
Quick-change sectional concave		○	○	○	○
Area	(m²)	0.86	0.86	1.04	1.04
Number of bars		14	14	14	14
Angle of wrap Opti-Thresh™ system open	(°)	85	85	85	85
Angle of wrap Opti-Thresh™ system closed	(°)	121	121	121	121
<b>Beater</b>					
Four paddle / pins beater drum		● / ○	● / ○	● / ○	● / ○
Diameter (m)		0.395	0.395	0.395	0.395
Beater concave area	(m²)	0.286	0.286	0.342	0.342
Synchronisation with drum speed		●	●	●	●
<b>Rotary Separator</b>					
Diameter (m)		0.59	0.59	0.59	0.59
Speed	(rpm)	400 / 760	400 / 760	400 / 760	400 / 760
Quick speed change without tools		●	●	●	●
Concave area (including rake)	(m²)	0.84	0.84	1.01	1.01
Multi-Thresh™ system		●	●	●	●
Total powered separation area	(m²)	1.988	1.988	2.387	2.387
Straw Flow™ beater		○	○	○	○

MODELS		CX5080	CX5090	CX6080	CX6090
<b>Strawwalkers</b>					
Number		5	5	6	6
Separation area	(m²)	5.38	5.38	6.45	6.45
<b>Cleaning</b>					
Smart Sieve™ self levelling: cleaning system automatic ker nel size adaptation		O	O***	O	O
Side slope correction on Pre- and Top sieve	(%)	25	25	25	25
Grainpan removable from front on fix cleaning shoe		O	O	O	O
Grainpan removable from front on Smart Sieve™ cleaning shoe		●	●	●	●
Pre-cleaning system		●	●	●	●
Total area under wind control FS	(m²)	4.321	4.321	5.207	5.207
Remote control sieve setting		O	O	O	O
<b>Levelling system</b>					
Optional Laterale Slope Levelling system (Side-Hill)	(%)	–	18	–	18
Wide Hillside Levelling system (Side-Hill, Up-Hill, Down-Hill) - overall width = 4.0m	(%)	–	38 / 30 / 10	–	–
Narrow Hillside Levelling system (Side-Hill, Up-Hill, Down-Hill) - overall width = 3.5m	(%)	–	33 / 30 / 10	–	–
<b>Cleaning fan</b>					
Opti-Fan™ system		●	●	●	●
Number of blades		6	6	6	6
Variable speed range - Optional low	(rpm)	165 - 420	165 - 420	165 - 420	165 - 420
- Standard high	(rpm)	400 - 1000	400 - 1000	400 - 1000	400 - 1000
Electrical speed adjustment from the cab		●	●	●	●
<b>Return system</b>					
High capacity grain elevator back to drum		●	●	●	●
Returns indication on IntelliView™ III monitor		●	●	●	●
<b>Grain elevator</b>					
High capacity grain elevator with heavy duty chain & flaps		●	●	●	●
<b>Grain tank</b>					
Capacity / Hillside version	(l)	7000	8000 / 7000	8000	9300
Central filling, folding bubble-up extension		●	●	●	●
<b>Unloading auger</b>					
Overtop unloading tube (4.75m)		●	●	O	O
Overtop unloading tube (5.50m)		O	O	●	●
Unloading speed / Hillside version	(l/s)	90	100 / 90	100	100
Grain sample inspection door		●	●	●	●
Grain tank fill warning device		●	●	●	●
Unloading auger swivel reach	(°)	105	105	105	105
<b>Engine* compliant with Tier 4 emission regulations</b>					
Selective Catalytic Reduction (SCR) system		●	●	●	●
Injection system		common rail	common rail	common rail	common rail
Gross engine power @ 2100rpm - ISO 14396 - ECE R120	[kW/hp(CV)]	175/238	200/272	200/272	220/299
Maximum engine power @ 2000rpm - ISO 14396 - ECE R120	[kW/hp(CV)]	190/258	220/300	220/300	245/333
Governor type		electronic	electronic	electronic	electronic
Fuel consumption measuring and read-out on IntelliView™ III monitor		●	●	●	●
Air compressor		O	O	O	O
Engine blow off system		O	O	O	O
<b>Fuel tanks</b>					
Diesel capacity / AdBlue capacity	(l)	580 / 110	580 / 110	580 / 110	580 / 110
<b>Transmission</b>					
		hydrostatic	hydrostatic	hydrostatic	hydrostatic
Gearbox		3-speed	3-speed	3-speed	3-speed
Hydrostatic hytron pump control		electronic	electronic	electronic	electronic
In-line gearshifting		●	●	●	●
Cruise control mode		●	●	●	●
Differential lock		O	O**	O	O**
Powered rear wheels		O	O	O	O
Maximum speed	(kph)	30	30	30	30
<b>Residue management</b>					
Dual-Chop™ straw chopper		O	O	O	O
Remote adjustable deflectors		O	O	O	O
Chaff spreader		O	O	O	O
<b>Dimensions</b>					
With traction wheels (****)		650/75 R32	710/75 R34	710/75 R34	710/75 R34
Maximum height in transport position	(m)	3.930	3.990***	3.990	3.990
Maximum width - transport	(m)	3275	3265**/****	3500	3500**
Maximum length with extended unloading tube without header	(m)	8760	8760	8760	8760
<b>Weight</b>					
Standard version less header and less straw chopper	(kg)	12300	12400	13200	13400
Hillside version less header and less straw chopper	(kg)	–	14000	–	–
Laterale version less header and less straw chopper	(kg)	–	13900	–	14700

● Standard ○ Optional – Not available

\* Developed by FPT Industrial

\*\* Not available on Laterale versions

\*\*\* Not available on Hillside version

\*\*\*\* Traction wheels other than those mentioned are also available, depending on the market (620/75-R30; 320/75-R34; 710/75-R34 ; 800/65-R32; 900/60-R32; 30.5 x 32; 1050/50-R32)

# NEW HOLLAND TOP SERVICE: CUSTOMER SUPPORT AND CUSTOMER INFORMATION



**TOP AVAILABILITY.**  
If you need information, or have an out of hours question, ring our toll-free number\*. All day, every day, we are just a call away.

**TOP SPEED.**  
Express parts delivery: when you need it, where you need it!

**TOP PRIORITY.**  
Fast-track solution during the season: because your harvest can't wait!

**TOP SATISFACTION.**  
We drive and track the solution you need, keeping you informed: until you are 100% satisfied!

 **TOP SERVICE**  
**00800 64 111 111**

\* Calls to the Top Service team are free from landlines in the United Kingdom and Republic of Ireland. UK-based mobile calls are also free, but Republic of Ireland mobile users should call **01 2421881** and this will be charged at your standard network rate.

**For more details, ask your New Holland dealer!**

AT YOUR OWN DEALER



**YOUR SUCCESS - OUR SPECIALTY**

Visit our web site for UK: [www.newholland.com/uk](http://www.newholland.com/uk) - for ROI: [www.newholland.com/ie](http://www.newholland.com/ie)

The data indicated in this folder are approximate. The models described here can be subjected to modifications without any notice by the manufacturer. The drawings and photos may refer to equipment that is either optional or intended for other countries. Please apply to our Sales Network for any further information. Published by New Holland Brand Communications. Bts Adv. - Printed in Italy - 02/11 - TP01 - (Turin) - **102001/INB**