

HP
176-275 | **MF7200**

The MF ACTIVA Combine; cost-effective harvesting flexibility
Now 6 models, with 5 or 6 straw walkers



VISION INNOVATION LEADERSHIP QUALITY RELIABILITY SUPPORT PRIDE COMMITMENT



MASSEY FERGUSON

Straightforward combines that simply get the job done

Massey Ferguson's enlarged ACTIVA range of combine harvesters are built using proven technology, drawn from over 40 years experience of designing and engineering harvesting equipment. They provide growers with a highly cost-effective and flexible harvesting solution.

Even the most demanding harvest conditions are handled with ease and in comfort, with built-in reliability ensuring the job gets done sooner rather than later.

All six models are capable of harvesting a wide range of crops, including cereals, grass seed, maize and sunflowers – all to the same high standards.

Harvesting can often be a race against time, so it makes sense to select a combine that you can depend on for efficient performance with minimal maintenance. There's certain to be an MF ACTIVA model that's perfect for your farming operation.

Build Quality + Reliability = High Performance

Stringent quality control procedures throughout the production process ensure that every MF ACTIVA combine leaves the factory capable of delivering complete peace of mind and retaining a high residual value.

These machines are built around an immensely strong, rigid chassis, underlining their suitability for harvesting cereals, maize – even rice; an abrasive crop that demands considerable durability and strength of the combine.

Every component has been designed or specified for maximum dependability and long life. Many of the parts that come into direct contact with the crop are of increased thickness and often upgraded by the use of harder wearing material.

In addition, more than 80% of the machine is galvanized and painted prior to being assembled, further enhancing the combine's longevity and resale value.



The ACTIVA range

Model	Horsepower	Straw walkers	Grain tank capacity
MF ACTIVA 7240	176	5	5200
MF ACTIVA 7244	226	5	7000
MF ACTIVA 7245	243	5	7000
MF ACTIVA 7245 S	243	5	7000
MF ACTIVA 7245 S AL	243	5	7000
MF ACTIVA 7246	243	6	7500
MF ACTIVA 7247 S	275	6	8800

A smooth first contact

The multi-crop FreeFlow cutting tables on MF ACTIVA combines are designed for high capacity and long-term durability.

Available in widths from 4.2 to 7.6 metres, the FreeFlow cutting tables are engineered down to the smallest detail. The reel bar ends are protected by caps to stop them wrapping around which may lead to blockages - a simple, effective design.

The table is built around a solid welded frame with individual panels bolted on, allowing easy replacement when eventually required. With this degree of strength comes reliability, a long working life and low running costs.

First contact with the standing crop is made by a high performance, self-cleaning Schumacher knife, giving a decisive cut before feeding into a large diameter table auger.

Feathering fingers along the full length of the auger ensure even distribution of the crop as it moves into the main elevator. The cutter bar operates at 1220 strokes per minute (equating to 1.73 metres/second) to provide a clean cut in all conditions with a very low power requirement.

All reel adjustments are made using the hydro lever in the cab, with automatic cutting height control as standard (with the exception of the new MF 7240 model) to optimise performance on all types of terrain.

An Auto Level table – an option on ACTIVA models, standard on ACTIVA S – allows table deviation of up to 8%, ensuring perfect alignment at all times.



01 Double serrated knives are protected by closed knife fingers for maximum strength and good performance.

02 The multi-coupler is standard for MF ACTIVA S models and optional for MF ACTIVA models. With one action all hydraulic connections linked.

03 Automatic height control (Terra Control) for comfortable work in all conditions.



01

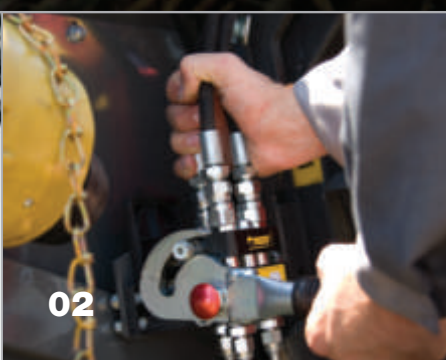

02



03

Threshing system – the heart of the combine

Massey Ferguson's design engineers have applied meticulous attention to this critical area of operation.



A strongly constructed cylinder, with eight rasp bars and a heavy-duty concave, ensure highly efficient threshing of a wide range of crops.

The concave's rear section has half the number of wires as on the front section, providing the optimum balance between high threshing ability and the free flow of grain through the concave.

Uniquely, the front and rear of the ACTIVA's concave can be adjusted independently from the cab, allowing the operator to select the appropriate settings for greater output and minimal crop damage. With this system, it is possible to work with the concave in the parallel position to boost output when conditions allow and preserve straw quality.

The ABC Module

This innovative component is located beneath the rear beater and offers several advantages:

- It provides an additional 14 degrees of concave wrap, so increasing threshing capacity.
- It controls the flow of straw onto the walkers from the rear beater, improving separation.

- Its angle of operation can be adjusted to account for straw length and moisture levels, optimising separation on the walkers.

MF ACTIVA S - Advanced threshing system

MF ACTIVA S models feature the Power Feed Roller (PFR), which improves crop transfer between header and elevator by distributing the crop over the full width of the elevator housing.

In addition, ACTIVA S combines have the patented Multi Crop Separator plus (MCS Plus), a system that allows the concave to be removed completely for sustained performance in wet conditions or high yield situations.

Versatile straw management

The threshing and separation processes on MF ACTIVA combines can be adjusted to provide a gentle straw treatment – a particularly useful feature on farms where the straw is to be used for livestock bedding. Even under difficult harvesting conditions, such as when the straw is dry or brittle, the best quality is always achievable.

This also ensures that a high straw yield per hectare is generated and a good swath for baling is produced.

(On the subject of baling, Massey Ferguson remains at the forefront of baler technology and builds a wide range of square, large square and round balers – there's certain to be one that meets your requirements precisely so talk to your MF dealer).

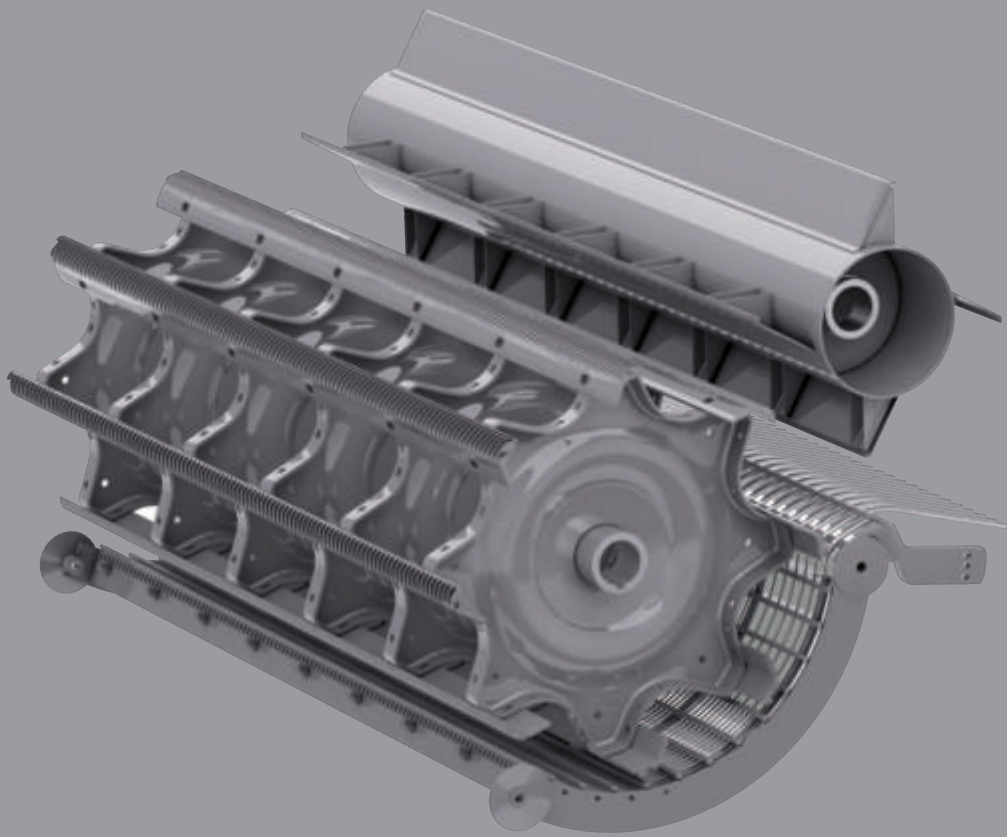

01

01 Threshing drum of the MF ACTIVA combine with the ABC Module for increased separation.

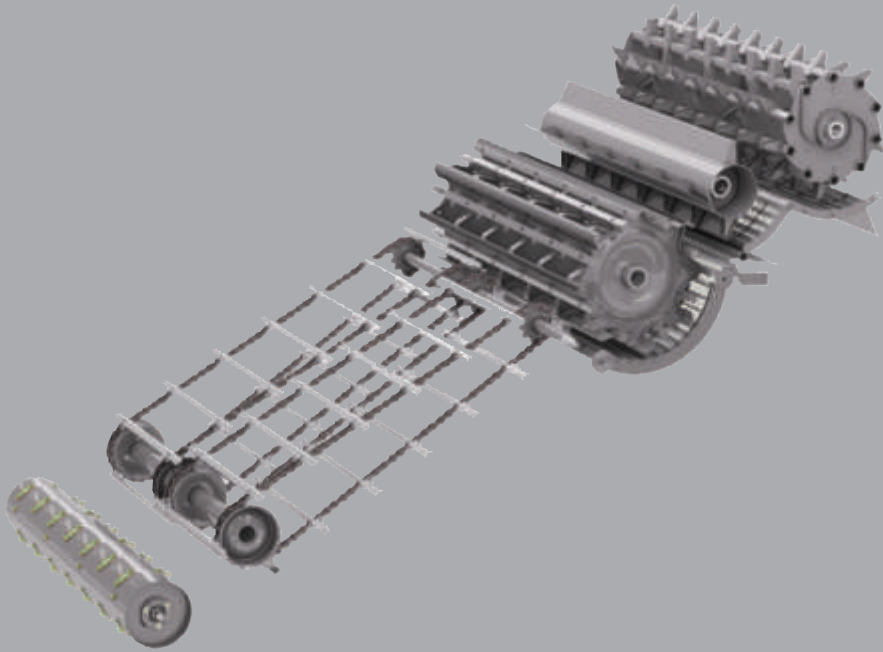

02

02 MF ACTIVA S threshing system with Power Feed Roller (PFR) and Multi Crop Separator Plus (MCS Plus).

03 MCS Plus turned in for sustained performance in wet conditions and high yield situations.

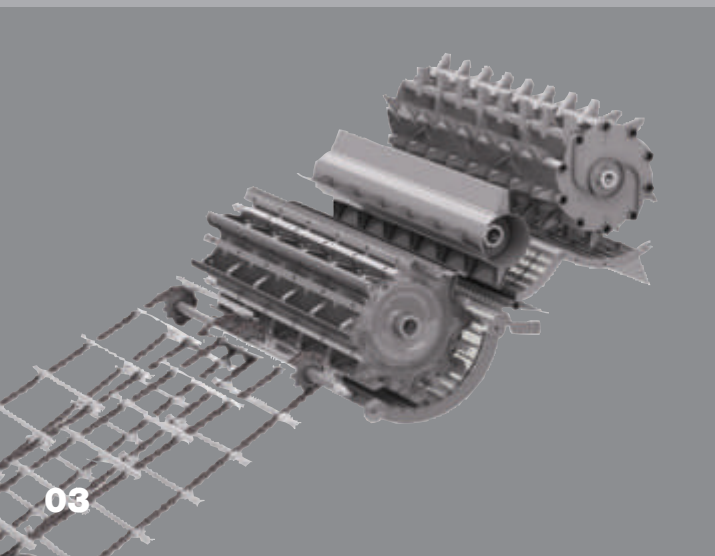

03

04 MCS Plus turned out optimises performance in dry conditions and "easy-to-thresh" crops.

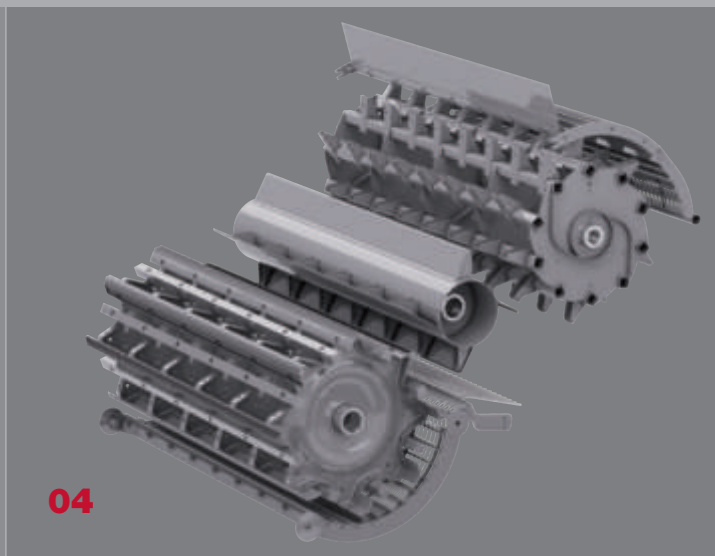

04

Achieving the best possible sample

One of critical factors in the harvesting process is to maintain a consistently good grain sample. Massey Ferguson's threshing, separation and cleaning system helps to ensure this goal is achieved – in all harvesting conditions.

Grain pan

The motion of the pan ensures the grain stays at the bottom with the lighter material and chaff remaining at the top. The grain pan is the same width as the threshing drum for maximum output while the high longitudinal dividers ensure an even feed from the pan to the sieves in sloping conditions.

Sieves

High Capacity Sieves (HC Sieves) move in opposite directions and deliver an optimum airflow with high adjustment tolerance at the same time. In dry conditions particularly, and when the straw is short and dry, the sieves still produce the best possible grain sample at high capacity. High separators on the top and bottom sieves maintain an even layer of material – even when working on slopes.

Fan

The powerful fan has three inlets – one on each side and another on the top – distributing airflow over the complete width for maximum efficiency. It can be adjusted from the cab between 350 and 1050 rpm and there's the option for running the fan at lower speeds in the 270-840 rpm range for lighter crops.

A choice of 5 or 6 Straw Walkers for efficient separation

Long, durable straw walkers are hot-dip galvanised for high separation performance and long life. Each one features four 210 mm-high 'active steps' with 150 mm travel and extra large vents for efficient thinning out of the straw mat.

Thicker metal is used for the front steps to deal with the flow of straw coming from the Active Beater Concave (ABC) module, while the fully-welded walkers are of closed bottom design, ensuring great strength of construction, improved reliability and an even feed of the grain pan.

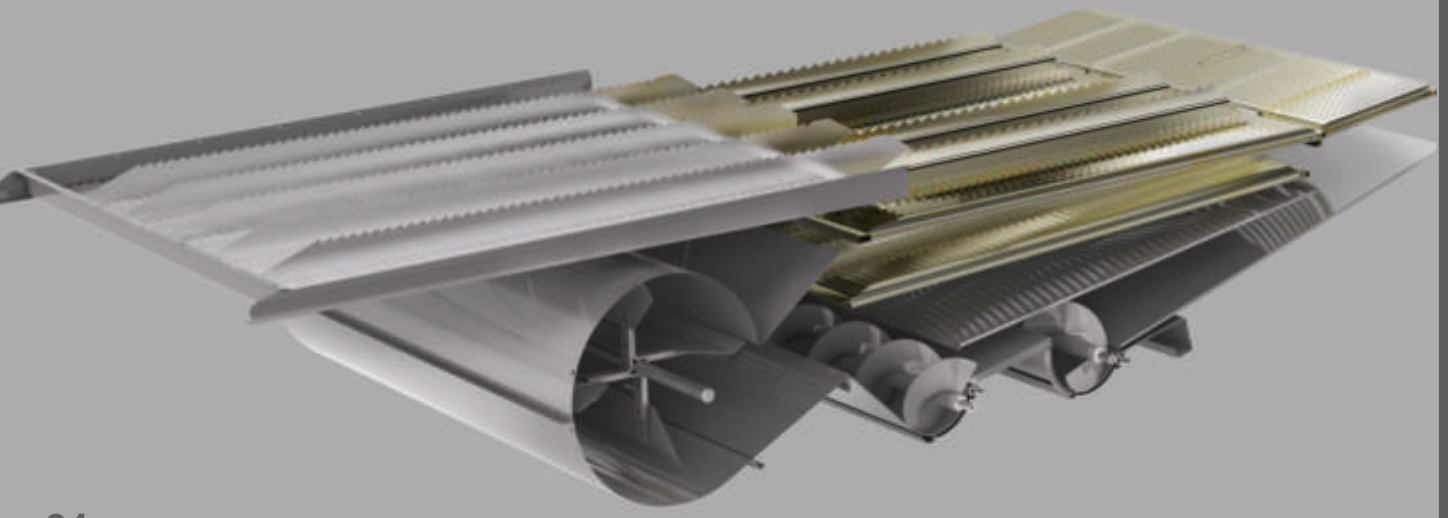

01

01 The fully-integrated cleaning system produces quality samples with high-output.



02

02 The powerful fan is mounted directly on the chassis for a reliable and vibration-free functionality.



03

03 Vertical tags on the High Capacity Sieves (HC Sieves), prevents short straw from overloading the cleaning system.

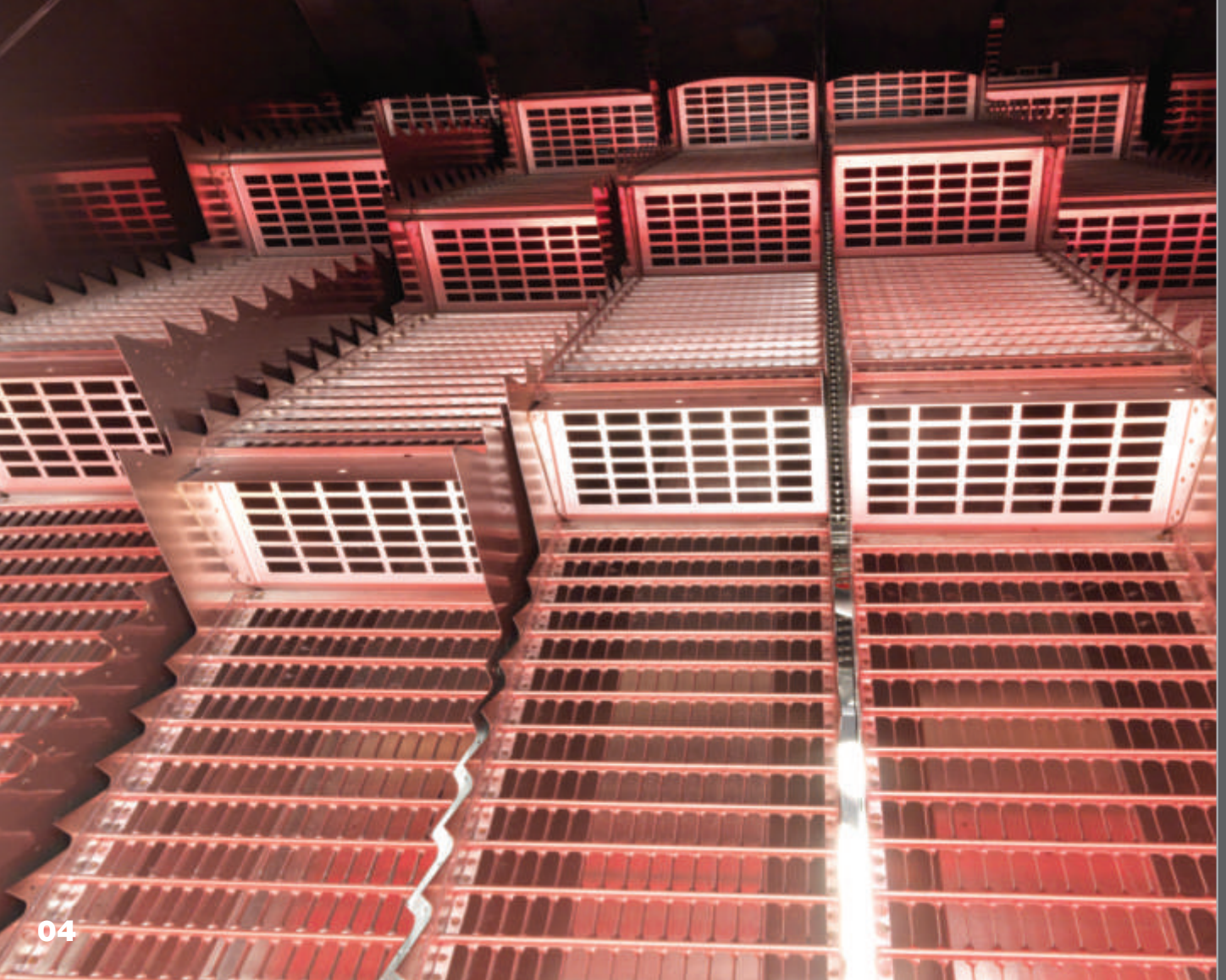

04

04 Four straw walker steps with 210 mm ensure high separation performance.

Handling residues to cut cultivation costs

All MF ACTIVA models are equipped with a multi-adjustable straw chopper, designed to give unmatched chopping/spreading capability, and making these combines ideal for subsequent min-till operations.

The double serrated rotating knives produce superb chop quality from a very low power requirement. The stationary knives and straw chopper hood can be quickly adjusted to ensure full control of quality and spread, and an adjustable dimple plate can deflect the chopped straw back up into the rotating knives for a finer cut.

The straw chopper is engaged automatically and simultaneously with the threshing system, once the straw deflector plate and chopper hood are in the correct position. It's very quick and easy to convert the chopper when harvesting maize merely by changing the speed and adjusting the deflector plates in the hood.

A chaff spreader is an option on all models.



01



02



03



04

01 Unrivalled chopping and spreading performance.

02 Gentle straw treatment ensures good straw quality for baling.

03 A quick change of the lever from swath to chopping.

04 Double serrated knives guarantee excellent chopping quality.

Ease of unloading

With grain tank capacities of up to *8800 litres, these combines unload at an impressive rate of 85 litres/sec and the 4.0m auger provides more than enough unloading height (4.20m) and reach to fill high-sided trailers.

*on the new MF ACTIVA 7247 S model

With grain tank capacities of up to 8800 litres (on the new MF ACTIVA 7247 S model) these combines unload at a rate of 85 litres/sec and the 4.0m auger provides more than enough unloading height (4.20m) and reach to fill high-sided trailers. A grain level alarm informs the driver when the grain tank is full.

Wear is kept to a minimum as the auger flights are manufactured with Hardox steel to extend their working life. In fact, wherever there are changes of direction in the grain handling zones the auger flighting is double thickness. The elevator end caps are bolted to facilitate quick and easy replacement.

A large window in the rear of the cab allows the operator to monitor

quality and tank level, and there's an additional inspection hatch close to the cab entrance.

Powerful engines; smooth transmissions

Driving ACTIVA combines through all harvesting conditions are highly fuel efficient engines, reliably delivering all the power required to get the crop into store in the shortest possible time.

Centralised radiators ensure extremely effective cooling of the engine, hydraulics and air conditioning. A rotary screen flips up for easy cleaning, while a dust extractor maintains free airflow even in the dirtiest conditions. The ACTIVA range transmission has a 3 speed mechanical unit with hydrostatic drive.

The ACTIVA S benefits from a 4 speed unit with slightly higher road speed and also offers a wider speed range for different conditions. The gear change lever is conveniently positioned to the right of the driver.



01

01 The ACTIVA range can unload at a high capacity of 85 litres/minute.

02 Grain sample hatch.

03 Large capacity grain tank with easy access for cleaning.

04-05 Easy access for servicing and maintenance in the engine compartment.



02



03



04



05

Designed for quick and easy maintenance

All ACTIVA combines are simple and straightforward to maintain as the number of drives has been designed to a minimum. In addition, there are just four greasing points that need daily attention.

Tanks and fillers for various fluids are ideally located for checking levels or topping up. The same applies for the engine air filter.

Large, hinged panels provide easy access to machine components

and the simplicity of the drives means belts can be replaced quickly without the need for special tools or training.

The main drive engagements for the threshing unit, table, unloader and straw chopper are simple, over-centre belt arrangements, where tension is held by spring pressure, requiring simple spring-length checks for adjustment.

An aluminium ladder, giving access to the engine bay, can be detached

and moved around the combine to reach other components.



01

01-02 Checking levels, topping up and changing filters is fast and easy.

03 Detachable ladder for access to the machine.



02



03

Maximum comfort for a stress-free harvest



High levels of operator comfort and safety, together with thoughtful positioning of controls, a panoramic view and a constant flow of harvesting information, means the ACTIVA's cab is truly class-leading.

With air conditioning, heating and electrically adjustable mirrors, the cab's long list of features also includes an air-suspended seat (MF ACTIVA S), adjustable steering

column and comfortable training seat (not on the MF 7240).

The AgritronicPlus monitor and the right-hand console provide all the information needed by the operator throughout the harvesting process, including harvested area, engine rpm, losses, etc. Clearly identified cutting table controls are grouped around the hydro lever, with additional controls allowing easy adjustment

of functions such as drum speed, concave position and fan speed.



01 The right-hand side console and multi-function lever.

02 Agritronic Plus monitor provides quick and easy information to the driver.

03 The ACTVA cab for round the clock comfort.

The wonder of Auto Level

The MF 7245 S AL ACTIVA model comes with the innovative full machine levelling system as standard.

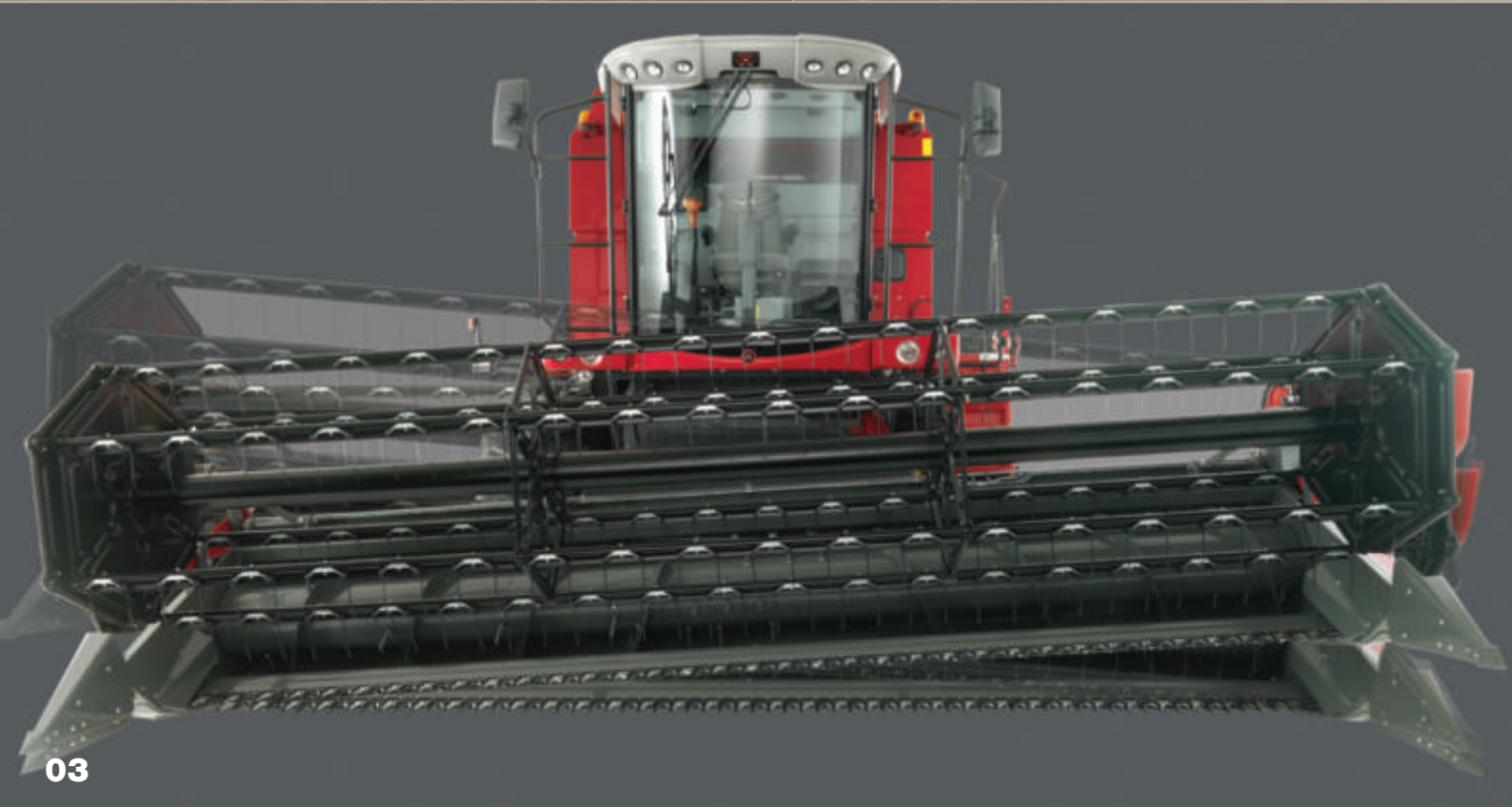

This ingenious system levels the combine rump across slopes by pivoting the front final drives. This correction feature makes it possible to work across slopes of up to 20 per cent.

Taking account of the extreme terrain these combines are capable

of working in, combine harvesters with Auto Level can be fitted with a powered rear axle to give genuine 4wd performance, more positive steering control and improved traction in difficult conditions.

The higher output Activa S offers flexibility and performance for

customers and contractors where there is marginal land to be harvested.



01 Work on slopes of up to 20% gradient with Auto Level.

02 The combine rump will level over slopes.

03 The Auto Level table system.

04 Auto Level at work.

The new MF 7240 ACTIVA

This new introduction to the ACTIVA range aims to meet the requirements of smaller scale arable enterprises and mixed farms whilst still offering high-powered, quality harvesting.



The MF 7240 ACTIVA combine boasts a straight-forward, uncomplicated design and provides cost-effective combine ownership at the highest levels of durability and reliability.

Powered by a highly fuel efficient 176 horsepower engine, the MF 7240 ACTIVA offers the usual high standard of features including five straw-walkers; built for reliable, long-term operation.

It is simple to operate too, with no superfluous functions or controls.

All the main functions are monitored by a clear and concise electronic display. For added comfort, air conditioning is a standard yet essential feature within the cab.

All the main threshing elements are engaged mechanically, as is the concave adjustment which can be adjusted in the cab.

Threshing is achieved by a conventional drum and concave which feeds the straw mat onto the five straw walkers for final separation.

Like all Massey Ferguson combines, the ACTIVA 7240 is equipped with a turret unloading auger that empties the 5,200 litre capacity grain tank quickly and precisely.



MF 7200 ACTIVA

features

01 FreeFlow Table

To improve cutting in difficult conditions, the table angle can be altered. Working with the high-speed Schumacher knife, crop can be gathered easily by the large diameter auger fitted with full length retractable fingers.

02 Main Crop Elevator

The heavy-duty crop elevator is built for maximum durability in the toughest harvesting conditions.

03 Threshing Concave

The threshing concave is a unique, independent, adjustable concave which enables front to rear alteration to maximise crop threshing and separation.

04 High Inertia Threshing Drum

The ACTIVA uses a large diameter drum. This maintains an even speed in difficult, undulating conditions - maximising threshing ability, output and reducing fuel consumption.

05 Straw Walkers

Our straw walkers are longer with high steps and active walls to maximise grain separation and increase output.

06 Cleaning System

Clean samples can be obtained from the large cleaning and high performance sieves.

07 Chopper

Using 4-rows of serrated knives on the rotor and serrated stationary knives with a high peripheral speed, crop is chopped finely with an even spread.

08 Cab

The ACTIVA cab offers long harvesting days with comfort as standard; all functions are easy to operate and the cab offers incredibly low noise levels.

09 Grain Tank

The grain tank maintains clean grain discharge, adequate volume and prevents water from entering.

10 Engine

For optimum performance, reliability and low fuel consumption, powerful, fuel efficient engines are used.

11 Unloader System

Getting grain off the machine is as important as getting it in. The 'turret' un-loader prevents grain damage whilst maintaining high-speed delivery.

12 Serviceability

Delivering low harvesting costs is essential on a machine. This can be achieved with reduced component numbers, simplicity, and great reliability with easy access. Daily maintenance is kept low due to less components.

13 Power Feed Roller (PFR)

Unique to the MF combine, the Power Feed Roller improves the feed from the header to the elevator whilst giving even crop material to maximise threshing and output.

14 Multi Crop Separator Plus (MCS Plus)

A rotary separator is fitted behind the beater to give centrifugal separation of the grain and to agitate the straw on the walkers, increasing separation and achieving higher outputs.

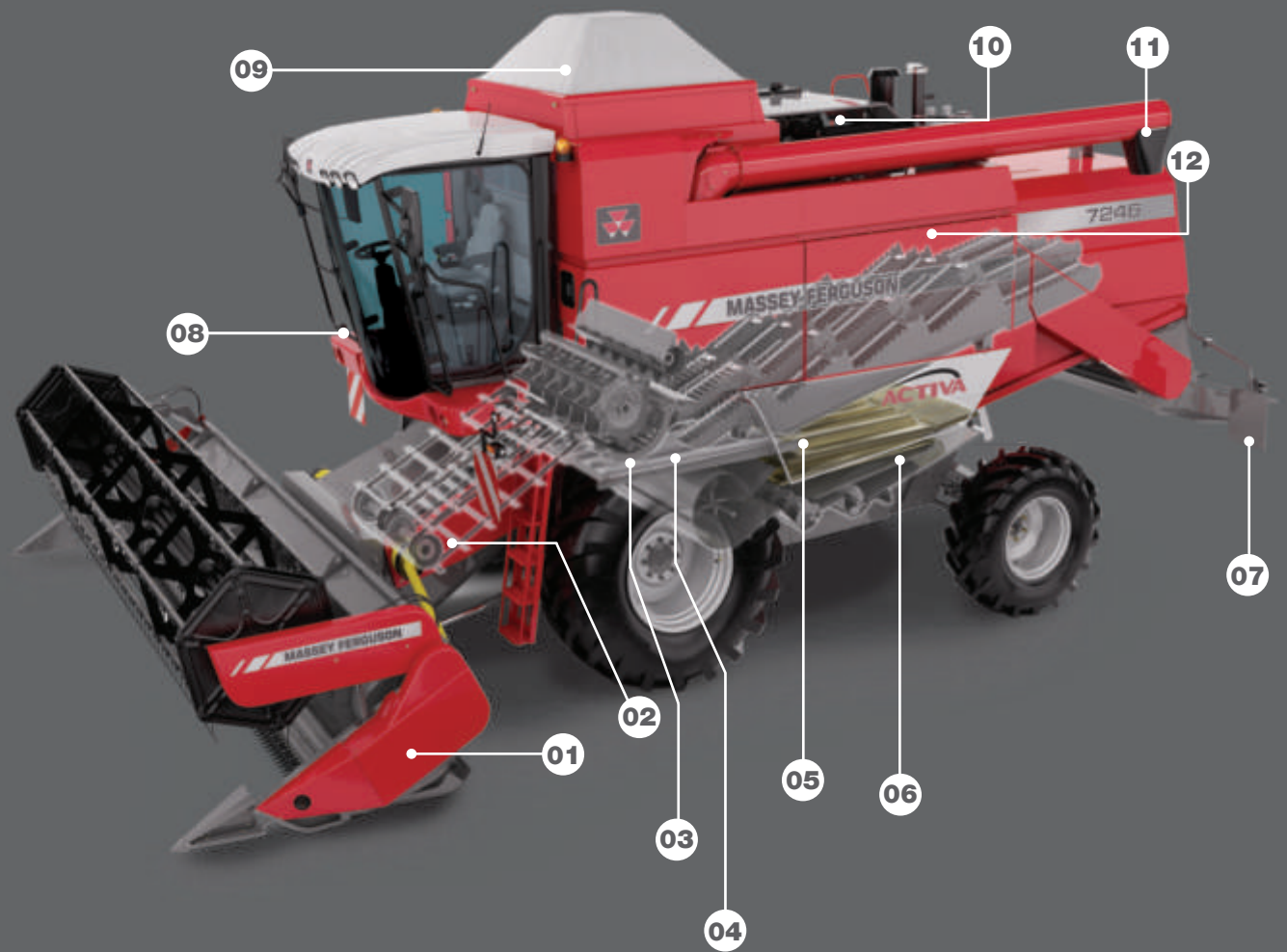

01

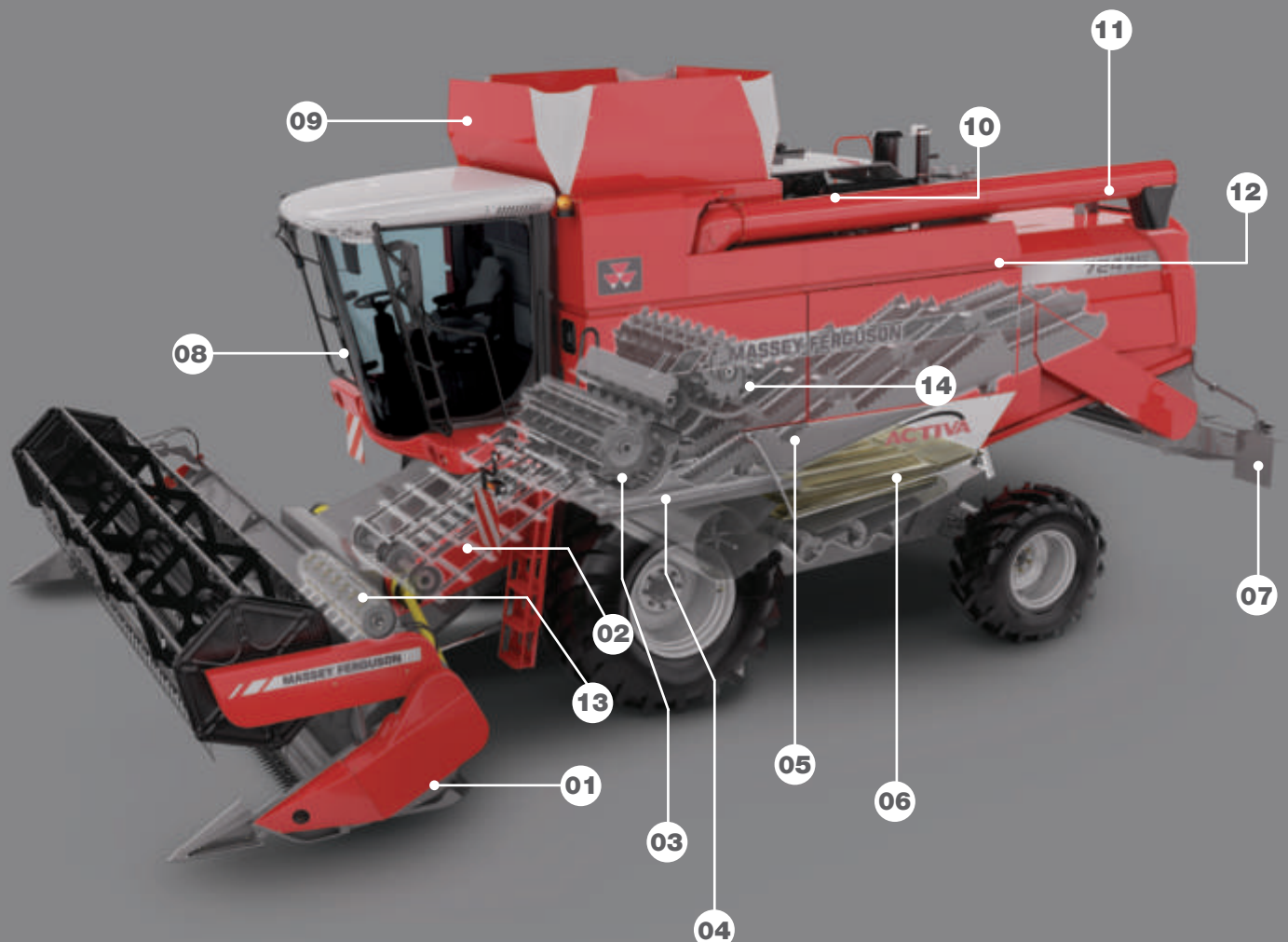

02

Customer support

Dedicated service and dynamic support

Massey Ferguson is a true, global brand with machines operating all over the world, and behind every Massey Ferguson machine is the powerful after sales support of AGCO's Customer Support organisation.

Industry benchmarking shows that AGCO offers customers world-class parts and service support, and this is never truer than in support of our harvest machinery both in and out of season.

In season excellence

The Harvest Support Programme is designed to be extremely dynamic and able to adapt immediately to changing conditions. Each harvest experience in every country is used to continuously enhance the comprehensive service. Key elements include:

- A dedicated harvest parts warehouse guaranteeing superb parts supply and availability, and enabling a direct and rapid logistical response.
- 24/7 AGCO Parts warehouse and Customer Service facilities for MF European combine markets.
- Dealer direct access to on-line parts ordering 24/7 with full visibility of parts availability throughout the European warehouse network round-the-clock.
- Exceptional services such as late cut-offs, special transport, 'Eurodirect' deliveries throughout Europe direct to MF dealers and customers, and collection services.
- Specialist technicians with expert product knowledge supporting local markets.
- Local dealer commitment to the highest levels of service by operating 'out of hours' parts and service support.

Year round distinction

Naturally we recognise that supporting our harvest equipment goes beyond the harvest period.

All Massey Ferguson machinery benefits from year round focus in the form of both the exceptional standards provided by AGCO Parts as well as specific servicing packages:

- Industry-leading parts supply through AGCO Parts' state-of-the-art warehousing and logistics.
- Genuine parts from AGCO Parts, the only genuine supplier, guaranteeing the right fit, first time, every time.
- Well-qualified parts specialists and highly-trained service technicians providing dedicated service support and technical solutions.
- After sales solutions for all ages of machinery for maximum uptime in every situation.
- Specific focus on preventative maintenance through comprehensive pre- and post-season health checks.
- Long term reliability from affordable servicing and maintenance packages.

After sales support from AGCO Customer Support is about providing the best solution to our customers' needs through world-class parts and service; providing the local service to the global brand.



01



02



03



04



05

Our promise to you

Our mission at Massey Ferguson, since the company was founded, has been to design, engineer and manufacture reliable, trustworthy and innovative machinery. Machinery that people recognise the world over.

VISION

Our vision for the world of agricultural machinery has always been clear; to produce worthwhile and innovative solutions for professional farmers feeding the world. Always recognisable, the Massey Ferguson brand of products signifies technological advancement, enhanced design, strict testing and quality manufacturing which is consistently trustworthy and hardworking.

INNOVATION

We've always been one step ahead when it comes to innovation. Our founder, Harry Ferguson is proof of that.

Through continual questioning and analysis of customers' needs, our products are designed, tested and built to enhance productivity, efficiency and convenience, constantly pushing the boundaries of farm machinery.

From the simplest push of a button to technological innovations in engine and transmission efficiency, we strive to make life simpler for the operator.

LEADERSHIP

Massey Ferguson is the most widely sold agricultural machine in the world, making us the leaders in the agricultural arena. We've won awards for our class-leading technology and advancement in design and we're already driving ahead, environmentally and economically.

QUALITY

It takes certain distinctive attributes to make a quality product. At Massey Ferguson, this distinction starts at the drawing board and doesn't stop. Every stage of manufacturing, from the building and testing process to sourcing the best components, demands excellence. Our products and services meet the most stringent standards allowing us to deliver our promises, confidently.

RELIABILITY

We don't let a Massey Ferguson machine out of our sight until we are 100% sure it will perform to the high standards you expect. Only after rigorous and painstaking testing both in simulations and in the field, will we allow our products to leave the factory. Whatever you put your machine through, day after day, season after season, we can guarantee we've already tested those limits and gone beyond them.

SUPPORT

Agriculture can be a solitary business, that's why we make sure that you can get support whenever you need it and at crucial times of the year. Be assured of sustainability from more than 3,200 dealer outlets in over 140 countries and a comprehensive machinery distribution network, you'll be part of dedicated family of specialists who make it their business to give you genuine, top quality service support.

Equally, we won't let an opportunity slip through your fingers. If you have the commitment but not necessarily the financial resources to compete in today's market-driven climate then AGCO Finance could have the solution. Ask your local dealer for more information.

Financial options are market specific but can include leasing, hire purchase, contract hire and loan facilities.

PRIDE

Here at Massey Ferguson, pride means many things to us. It's in everything we do and it shows. It's in our proud heritage, our unique product design and our ongoing support to our customers.

COMMITMENT

We are deeply committed to delivering the highest of expectations and to build quality, reliable products with innovative features that are backed by the best support packages. Ultimately, we are committed to continuous growth and profitability for all, whilst recognising the needs of both large and small businesses through professionalism and quality.



Cutting table		MF 7240	MF 7244	MF 7245	MF 7246
Cutting width	(m)	4.20 - 5.40	4.20 - 7.60	4.20 - 7.60	4.80 - 7.60
Terra Control cutting height control		-	●	●	●
Auto Level table guidance		-	○	○	○
Cutting frequency	(stroke/min.)	1220	1220	1220	1220
Feed type		-	-	-	-
No. of chains		3	3	3	4
Fingers over entire width		●	●	●	●
Threshing system					
Drum width	(mm)	1340	1340	1340	1600
Drum diameter	(mm)	600	600	600	600
Threshing drum speed	(rev/min)	380 - 1210	380 - 1210	380 - 1210	430 - 1310
Wrapping angle threshing concave	degrees	120	120	120	120
Concave area	(m ²)	0.83	0.83	0.83	0.99
Electrical Concave setting		-	●	●	●
Independent setting front and back		●	●	●	●
Separation system					
Multi Crop Separator plus (MCS plus)		-	-	-	-
MCS plus width	(mm)	-	-	-	-
MCS plus diameter	(mm)	-	-	-	-
Total powered separation area	(m ²)	0.99	0.99	0.99	1.18
No. of straw walkers		5	5	5	6
No. of steps		4	4	4	4
Walker length	(mm)	4256	4256	4256	4256
Straw walker area	(m ²)	5	5	5	6
Total separation area	(m ²)	6.72	6.72	6.72	7.99
Cleaning system					
Fan type		Radial			
Fan speed	(rev/min)	350 - 1050			
Fan speed reduction kit	(rev/min)	270 - 840			
Returns material to drum		●	●	●	●
Total sieve area	(m ²)	4.67	4.67	4.67	5.58
Straw Management					
Straw chopper		●	●	●	●
64 knives		-	-	-	●
52 knives		●	●	●	-
Double serrated knives		●	●	●	●
Electrically adjustable deflectors		-	○	○	○
Chaff spreader		○	○	○	○
Single lever switch-over for straw chopper		●	●	●	●

- = Standard
- = Optional
- = Not applicable/available

Specifications

Every effort has been made to ensure that the information contained in this publication is as accurate and current as possible. However, inaccuracies, errors or omissions may occur and details of the specifications may be changed at any time without notice. Therefore, all specifications should be confirmed with your Massey Ferguson Dealer or Distributor prior to any purchase.

Cutting table		MF 7245 S	MF 7245 S AL	MF 7247 S
Cutting width	(m)	4.20 - 7.60	4.20 - 7.60	4.80 - 7.60
Terra Control cutting height control		●	●	●
Auto Level table guidance		●	●	●
Cutting frequency	(stroke/min.)	1220	1220	1220
Feed type		Power Feed Roller		
No. of chains		3	3	4
Fingers over entire width		●	●	●

Threshing system				
Drum width	(mm)	1340	1340	1600
Drum diameter	(mm)	600	600	600
Threshing drum speed	(rev/min)	380 - 1210	380 - 1210	430 - 1310
Threshing concave wrap angle	degrees	120	120	120
Concave area	(m ²)	0.83	0.83	0.99
Electrical Concave setting		●	●	●
Independent setting front and back		●	●	●

Separation system				
Multi Crop Separator plus (MCS plus)		●	●	●
MCS plus width	(mm)	1340	1340	1600
MCS plus diameter	(mm)	600	600	600
Total powered separation area	(m ²)	1.89	1.89	2.25
No. of straw walkers	(mm)	5	5	6
No. of steps		4	4	4
Walker length	(mm)	4256	4256	4256
Straw walker area	(m ²)	5.73	5.73	6.81
Total separation area	(m ²)	7.62	7.62	9.06

Cleaning system				
Fan type		Radial		
Fan speed	(rev/min)	350 - 1050		
Fan speed reduction kit	(rev/min)	270 - 840		
Returns material to drum		●	●	●
Total sieve area	(m ²)	4.67	4.67	5.58

Straw Management				
Straw chopper		●	●	●
64 knives		-	-	●
52 knives		●	●	-
Double serrated knives		●	●	●
Electrically adjustable deflectors		○	○	○
Chaff spreader		○	○	○
Single lever switch-over for straw chopper		●	●	●

Grain tank		MF 7240	MF 7244	MF 7245	MF 7246
Capacity	(l)	5200	7000	7000	7500
Unloading rate	(l/sec)	85	85	85	85
Unloading type		Turret unloading			
Swivel angle of unloading auger	degrees	100	100	100	100
Max. unloading height	(m)	4.20	4.20	4.20	4.20

Engine

Engine type	make	IVECO NEF			
Cubic capacity	(l)	6.7	6.7	6.7	6.7
Power	(kW/ hp) ⚙	129/ 176	166/ 226	179/ 243	179/ 243
Fuel tank	(l)	450	450	450	450

Drive

Hydrostatic drive		●	●	●	●
Number of gears		3	3	3	3
4 wheel drive		-	○	○	○

Cab

Mechanically suspended driver's seat		●	-	-	-
Air-suspended drivers seat		-	●	●	●
Training seat		-	●	●	●
Heating		●	●	●	●
Air conditioning		●	●	●	●
Agritronic plus		-	●	●	●
Monitor		●	-	-	-

Weights and dimensions

Height (transport position)	(mm)	4000			
Length with chopper	(mm)	8700			
Weight	* (kg)	10.300	10.800	10.800	11.500

Tyres

Front (standard)		620/75R30	620/75R30	650/75R32	650/75R32
Rear (standard)		405/70-20	405/70-20	460/70R24	460/70R24
Transport width with tyres:					
800/65R32	(mm)	-	3628	3628	3880
650/75R32	(mm)	3250	3250	3250	3490
620/75R34	(mm)	3195	3195	3195	3480
620/75R30	(mm)	3195	3195	-	-

● = Standard

○ = Optional

- = Not applicable/available

⚙ = ISO TR14396

* depends on equipment installed

Specifications

Every effort has been made to ensure that the information contained in this publication is as accurate and current as possible. However, inaccuracies, errors or omissions may occur and details of the specifications may be changed at any time without notice. Therefore, all specifications should be confirmed with your Massey Ferguson Dealer or Distributor prior to any purchase.

Grain tank		MF 7245 S	MF 7245 S AL	MF 7247 S
Capacity	(l)	7000	7000	8800
Unloading rate	(l/sec)	85	85	85
Unloading type		Turret unloading		
Swivel angle of unloading auger	degrees	100	100	100
Max. unloading height	(m)	4.20	4.20	4.20

Engine				
Engine type	make	IVECO NEF		AGCO SISU POWER
Cubic capacity	(l)	6.7	6.7	7.4
Power	(kW/ hp) [⊕]	179/ 243	179/ 243	202/ 275
Fuel tank	(l)	450	450	450

Drive				
Hydrostatic drive		●	●	●
Number of gears		4	4	4
4 wheel drive		○	○	○

Cab				
Mechanically suspended driver's seat		-	-	-
Air-suspended drivers seat		●	●	●
Training seat		●	●	●
Heating		●	●	●
Air conditioning		●	●	●
Agritronic plus		●	●	●
Monitor		-	-	-

Weights and dimensions				
Height (transport position)	(mm)	4000		
Length with chopper	(mm)	8700		
Weight	* (kg)	11.900	11.200	11.500

Tyres				
Front (standard)		650/75R32	650/75R32	650/75R32
Rear (standard)		460/70R24	460/70R24	460/70R24
Transport width with tyres:				
800/65R32	(mm)	3628	-	3880
650/75R32	(mm)	3250	3490	3490
620/75R34	(mm)	3195	-	3480
620/75R30	(mm)	-	-	-

MF 7200 highlights

Here's a quick reminder of some of the advanced features of the MF 7200 Series ACTIVA combines that further enhance their place firmly within the harvesting sector.

- 01** The MF ACTIVA range of combine harvesters are built on 40 years of proven technology and experience.
- 02** Seven models in the range, from 176 to 275 hp, all with large capacity grain tanks and 5 or 6 straw walkers.
- 03** FreeFlow cutting tables are available in widths from 4.2 to 7.6 metres.
- 04** High performance, self-cleaning Schumacher knife gives a decisive cut before feeding into a large diameter table auger.
- 05** Massey Ferguson's threshing, separation and cleaning system helps to ensure a consistently good grain sample – in all harvesting conditions.
- 06** A choice of 5 or 6 durable straw walkers ensures high separation performance and long life. Each one features four 210 mm-high 'active steps' with 150 mm travel.
- 07** All MF ACTIVA models are equipped with a straw chopper, designed to give unmatched chopping/spreading capability, and making these combines ideal for subsequent min-till operations.
- 08** With grain tank capacities of up to *8800 litres, these combines unload at an impressive rate of 85 litres/second.
- 09** Driving ACTIVA combines through all harvesting conditions are highly fuel efficient engines, reliably delivering all the power required to get the crop into store in the shortest possible time and with the minimum consumption of fuel.
- 10** The NEW MF 7240 ACTIVA combine boasts a straight-forward, uncomplicated design and provides cost-effective combine ownership at the highest levels of durability and reliability.

*on the new MF ACTIVA 7247 S model