



These fuel efficient units feature electronic *Common Rail* injection systems along with a Power Management system giving extra power for PTO work. The new engines offer outstanding torque characteristics resulting in greater performance and flexibility. Innovation is also incorporated into the new XtraSpeed transmission, the unique 8 speed powershift is available with a choice of mechanical (STD version) or electronic (E-PLUS version) range shifting. The XtraSpeed transmission provides 32 speeds and four synchromesh ranges with hydraulic reverse power shuttle

The electrohydraulically-engaged PTO, featuring a reversible shaft with 6/21 splines, provides two speeds of 540/1000 rpm, while the powerful electronically-controlled rear hitch ensures a maximum lift capacity of 10950 Kg. Optionally, the tractor may be equipped with a front hitch that provides a lift capacity of 3500 Kg for extra versatility.

The front axle, available either rigid or with electronically-controlled independent suspension system, offers a steering angle of 55° for improved manoeuvrability.

The closed-centre hydraulics feature a variable-displacement pump with 130 l/min flowrate and a maximum of five auxiliary hydraulic valves with timer and flow control.

If you want to become a *leader* in the agricultural machinery market, you must build tractors that meet the real needs of farmers.

With the new 190, 210 and 230 models, the McCormick TTX tractors mark a technological breakthrough in the over 200-hp tractor segment.

The TTX tractor range are powered by the new BetaPower 6.7L, 24-valve, 6-cylinder turbocharged engines.

Designed to meet the farmer's needs for maximum safety and comfort, the Deluxe cab offers exceptional all-round visibility. The highly efficient heating and air-conditioning system along with the deluxe air seat and ergonomically arranged controls make the perfect operators environment. In addition the optional hydraulic cab suspension further maximises the comfort of the cab, making the TTX tractor a pleasure to drive.

McCORMICK

	TTX 190 (T3) XTRASPEED	TTX 210 (T3) XTRASPEED	TTX 230 (T3) XTRASPEED
ENGINE			
TIER 3	BETAPOWER	BETAPOWER	BETAPOWER
ELECTRONIC HIGH PRESSURE COMMON RAIL	●	●	●
MAX. ENGINE POWER (ISO)	HP/KW 180/132	199 / 146	213 / 157
ENGINE POWER WITH POWER MANAGEMENT (ISO)	HP/KW 199 / 146	213 / 157	225 / 165
MAX. TORQUE (WITH POWER MANAGEMENT)	NM 774 (800)	800 (850)	850 (950)
TORQUE BACKUP (WITH POWER MANAGEMENT)	45% (38%)	38% (37%)	45% (42%)
DISPLACEMENT (CM3) /CYLINDERS/VALVES	6.728 / 6 / 24	6.728 / 6 / 24	6.728 / 6 / 24
FUEL TANK CAPACITY	LITRES 350	350	350
CLUTCH			
CLUTCH FORWARD REVERSE POWER SHUTTLE HIGT CAPACITY MUTI DISC CLUTCHES	●	●	●
TRANSMISSION			
XTRASPEED+REV. SHUTTLE: 32FWD+24REV (8 POWERSHIFT SPEEDS) (STD VERSION)	●	●	●
XTRASPEED+CREEPER+REV. SHUTTLE: 48FWD+40REV (STD VERSION)	○	○	○
AUTOROADING+REV. SHUTTLE: 32V+24R (8 POWERSHIFT SPEEDS) (E-PLUS VERSION)	●	●	●
ELECTRONIC RANGE SHIFT (E-PLUS VERSION)	●	●	●
REVERSE POWER SHUTTLE: UNDER LOAD	●	●	●
ELECTROHYDRAULIC PARK LOCK (STD / E-PLUS)	○/●	○/●	○/●
REAR ELECTROHYDRAULIC DIFF-LOCK	●	●	●
POWER TAKE-OFF			
PTO MULTI-DISC CLUTCH	●	●	●
ELECTROHYDRAULIC CONTROL	●	●	●
2 SPEEDS 540/1000 RPM	●	●	●
4WD FRONT AXLE			
RIGID TYPE	●	●	●
FRONT AXLE INDEPENDENT SUSPENSION	○	○	○
MAX. STEERING ANGLE	55°	55°	55°
TURNING RADIUS	MM 5.400	5.400	5.400
BRAKES			
OIL-IMMERSED ANNULAR PISTON REAR BRAKES - 6 DISCS	●	●	●
4 WD AUTOMATIC ENGAGEMENT ON BRAKING	●	●	●
"BRAKING BOOSTER SYSTEM" SERVO BRAKE	●	●	●
HYDRAULICS			
VARIABLE-DISPLACEMENT PISTON PUMP	●	●	●
TOTAL HYDRAULIC FLOW	LITRI/MIN 130 ● / 163 ○	130 ● / 163 ○	130 ● / 163 ○
MECHANICALLY/ELECTROHYDRAULICALLY OPERATED AUXILIARY VALVES (STD VERSION) STD/OPT	3/1	3/1	3/1
ELECTROHYDR. -OPERATED AUXILIARY VALVES WITH "CAN BUS SPOOL VALVE MANAGEMENT" (E-PLUS VERSION) STD	4	4	4
THREE POINT LINKAGE WITH "CAN BUS LIFT CONTROL"			
ELECTRONICALLY OPERATED	●	●	●
FUNCTIONS: POSITION CONTROL, INTERMIX, FLOAT POSITION, RIDE CONTROL	●	●	●
MAX. LIFT CAPACITY	KG 10.950	10.950	10.950
CAB AND DRIVING SEAT			
CAB "DELUX" WITH ELECTRONICALLY-CONTROLLED HYDRAULIC SUSPENSION	○	○	○
AIR-CONDITIONING	●	●	●
PNEUMATIC SUSPENSION SEAT	●	●	●
DIMENSIONS AND WEIGHTS			
STD FRONT TYRES	540/65R30	540/65R30	540/65R30
STD REAR TYRES	650/65R42	650/65R42	650/65R42
A - HEIGHT OVER CAB	MM 3000	3000	3000
B - WHEELBASE	MM 2873	2873	2873
C - MAX. LENGTH (WITH BALLAST WEIGHTS)	MM 5307	5307	5307
D - GROUND CLEARANCE 4WD	MM 470	470	470
E - MINIMUM WIDTH TO THE GROUND	MM 2415	2415	2415
TOTAL WEIGHT (WITHOUT BALLAST WEIGHTS)	KG 7700	7700	7700

Key: ● standard ○ option — not available

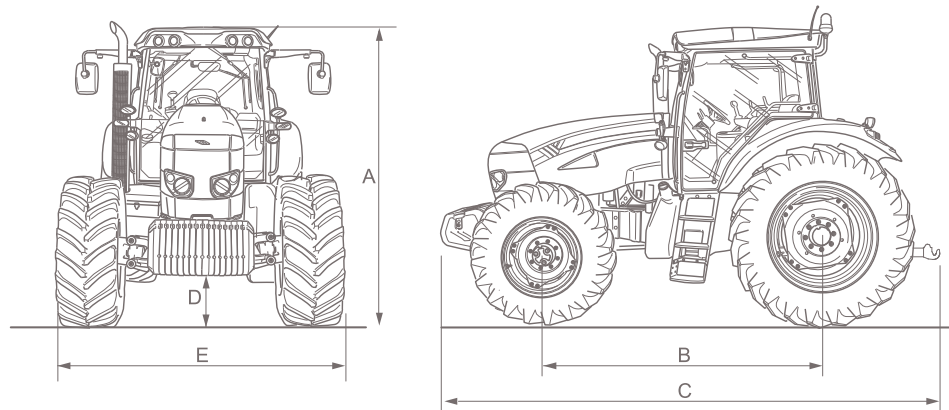

190-210-230 (T3)

TTX

XtraSpeed



McCORMICK



McCormick **TTX**,
all-round **innovation**



ENGINE

The new BETA-POWER 6-cylinder turbo engines are iso mounted within a rugged chassis frame. Equipped with high-pressure electronic COMMON-RAIL fuel injection system, they deliver 180, 199 and 213 HP (ISO), respectively.

The engine management system ensures optimum clean combustion and low emissions in line with TIER 3 regulations, while providing improved fuel economy and up to 40% torque rise.

Combined with the engine electronics, the Power Management system allows an automatic increase of both the power and torque available at the PTO.

The fully-tilting hood provides unrestricted access to the engine for routine service and maintenance (*fig. A*).

FRONT AXLE

The front axle can be optionally equipped with an electronically-controlled hydraulic suspension system that will ensure high speeds on rough terrains, while improving traction and manoeuvrability for enhanced comfort, safety and productivity (*fig. B*).



TRANSMISSION

The 'XTRASPEED' electronic transmission provides 32 speeds over four ranges and 8 powershift speeds on-the-go in each range. Equipped with reverse power shuttle, This transmission offers a choice of mechanical (STD version) or electronic (E-PLUS version) range shifting.

The electronic version (E-PLUS version) is controlled via a joystick that allows all ranges and electronic powershift speeds to be operated by simply pushing a button (*fig. C*).

The electronic system also features a "SKIP SHIFT" function allowing 'smart' shifting through all four ranges. An AUTORODING function provides automatic gear shifting during transport operations.

By selecting the right gear to suit the engine load and rpm, the AUTORODING function ensures simple and smooth driving, which maximises comfort and productivity while improving fuel economy.

The transmission is also equipped with a hydraulic REVERSE POWER SHUTTLE (*fig. D*) providing a total of 32 forward and 24 reverse speeds. On the electronic versions the shuttle gears may be programmed to further enhance shuttle operations. A creeper unit (available in the STD version) can also be factory fitted as an option to achieve 48 forward and 40 reverse speeds. A rocker switch ensures easy engagement of the creeper.

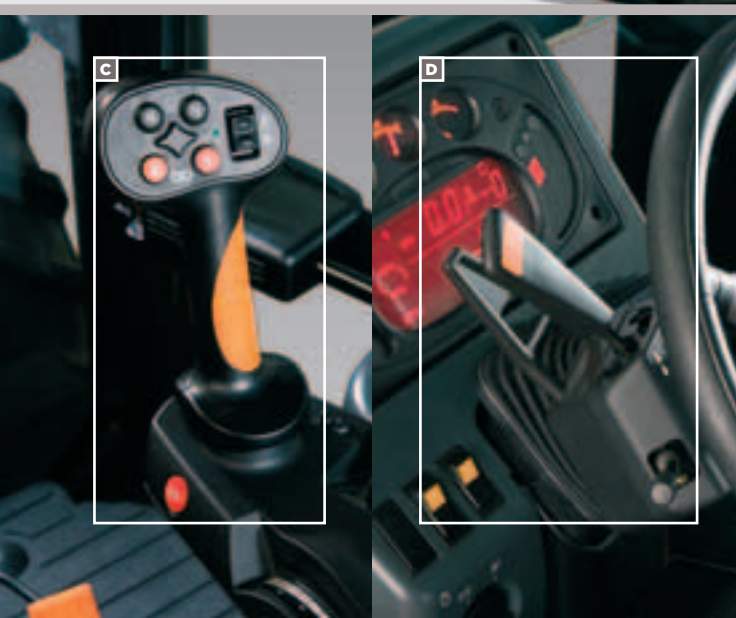





McCormick TTX,
best in class
for features

HYDRAULICS

The closed-centre hydraulic system with variable-displacement pump provides a flowrate of 130 l/min and ensures optimum operation of four rear hydraulic valves available (fig. E).

A higher capacity pump with 163 l/min is also available as an option. On the E-Plus version, the 4 auxiliary valves are electro-hydraulically controlled by the joystick controls located on the multi-function armrest (1 and 2) (fig. F). This armrest also incorporates the flow and timer controls which can be adjusted to give total implement control and maximize efficiency.

ELECTRONICALLY-CONTROLLED HITCH

With the main up down hitch control (S) conveniently located on the joystick (E-Plus models) it allows fingertip control of the three point hitch (fig. F). All models feature integrated controls on the right hand console (fig. G), for easy operation. The rugged design Cat. 3 linkage provides a lift capacity of 10950 kg.

POWER TAKE-OFF

The wet disc clutch, hydraulically operated via a pushbutton (P) (fig.F), enables smooth and progressive engagement of the PTO.

The POWER MANAGEMENT system, which utilises the engine electronics, allows the power and torque available at the PTO to be automatically increased under load by approximately 15 hp, resulting in enhanced performance and productivity.

An auto PTO function enables the PTO to engage and disengage automatically based on the position of the hitch for added convenience during headland manoeuvres.

CAB

The four-post cab with large, rear-hinged doors provides total all-round visibility and allows the operator to enter and exit with ease. It comes as standard with a powerful air-conditioning system integrated in to the roof, a fully adjustable steering wheel and air seat with multi-function armrest on the E-Plus version. The stylish interior and excellent sound-proofing make driving a pleasure.

The tractor may be supplied with an electronically-controlled hydraulic cab suspension system, which, combined with the independent front axle suspension, provides maximum driving comfort. (fig. H).

