



From plain to mountain, from open fields to row crops, the new McCormick CX-L and CX-LC (T3) tractors know no limits: lightweight, powerful and versatile, they are ideally suited to a variety of needs. All models are powered with the new, environment-friendly Yanmar 4TNV98 naturally aspirated and turbocharged "Tier 3" engines delivering up to 81.2 hp. The modular transmission is available in two options: mechanical, Speed Five, and electrohydraulic, Power Five, with De-Clutch Control and Reverse Power Shuttle. The CX-L range comes in two versions: CX-L, ideal for work on flatlands, and CX-LC specially designed for hillside operation. Both versions are available in four cabbed models: 70, 80 and 85.

Additional features of the CX-L range include a Fast-Run steering system, simultaneous rear and front diff-locks with hydraulic push-button engagement, a hydraulic PTO, a power lift with 3400kg lift capacity, a hydraulic system with four auxiliary valves and an optional front lift, making these tractors extremely functional for a variety of applications.

The comfortable "DELUXE" cab, with all-glass side doors hinged onto the rear post for all-round visibility, further enhances the performance and functionality of this tractor range. The CX-L is a true all-rounder, in which every detail has been designed to make work pleasant and easy.

McCORMICK

	CX70L (T3)		CX80L (T3)		CX85L (T3)	
	CX-L	CX-LC	CX-L	CX-LC	CX-L	CX-LC
	SYNCHRO SHUTTLE	POWER SHUTTLE	SYNCHRO SHUTTLE	POWER SHUTTLE	SYNCHRO SHUTTLE	POWER SHUTTLE
ENGINE						
YANMAR TIER 3 DIRECT-INJECTION						
MAX. POWER (ISO)	HP/KW	69,5 / 51,1	69,5 / 51,1	76,2 / 56	76,2 / 56	81,2 / 59,7
NET PTO POWER (ISO)	HP/KW	64 / 47*	64 / 47*	70,5 / 51,5*	70,5 / 51,5*	75 / 55*
MAX. TORQUE NM		224	224	285	285	298
DISPLACEMENT / NO. OF CYLINDERS	CM ³	3319 / 4	3319 / 4	3319 / 4 TURBO	3319 / 4 TURBO	3319 / 4 TURBO
FUEL TANK CAPACITY	LITRES	90	90	90	90	90
CLUTCH						
INDEPENDENT, DRY SINGLE-PLATE CLUTCH	INCH/(MM)	12/(304,8)	12/(304,8)	12/(304,8)	12/(304,8)	12/(304,8)
MECHANICALLY OPERATED		●	●	●	●	●
MULTI-DISC WET CLUTCH		●	●	●	●	●
DECLUTCH CONTROL: CLUTCH CONTROL BY BUTTON		●	●	●	●	●
TRANSMISSION						
MECH.REV.SHUTTLE + SPEED FIVE + CREEPER: 30FWD+30REV 40KM/H		●	●	●	●	●
MECH.REV.SHUTTLE + SPEED FIVE + POWER FIVE + CREEPER: 60FWD+60REV 40KM/H		○	○	○	○	○
HYDR.REV. SHUTTLE + SPEED FIVE + POWER FIVE + CREEPER: 60FWD+60REV 40KM/H		●	●	●	●	●
REVERSE POWER SHUTTLE UNDER LOAD		●	●	●	●	●
POWER TAKE-OFF						
HYDRA-PTO MULTI-DISK WET CLUTCH		●	●	●	●	●
2 SPEEDS: 540/750 RPM		●	●	●	●	●
GROUND SPEED PTO		●	●	●	●	●
4WD FRONT AXLE						
ELECTROHYDRAULIC 4WD ENGAGEMENT		●	●	●	●	●
MAX. STEERING ANGLE	DEGREES	55	60	55	60	55
TWIN-LOCK ELECTROHYDRAULIC DIFF-LOCKS		●	●	●	●	●
BRAKES (IBS - INTEGRAL BRAKING SYSTEM)						
REAR WET DISC GRAPHITE BRAKES - 8 DISCS		●	●	●	●	●
FRONT WET DISC GRAPHITE BRAKES - 4 DISCS		●	●	●	●	●
HYDRAULIC POWER LIFT						
MECHANICAL		●	●	●	●	●
ELECTRONIC		○	○	○	○	○
CLIFT CAPACITY WITH 2 ASSISTOR RAMS	KG	3400 STD	3400 STD	3400 STD	3400 STD	3400 STD
HYDRAULIC PUMP FLOW (POWER LIFT+STEERING)	L/MIN	54+27	54+27	54+27	54+27	54+27
CATEGORY		CAT 2	CAT 2	CAT 2	CAT 2	CAT 2
AUXILIARY VALVES STD/OPT		2/4	2/4	2/4	2/4	2/4
CAB AND DRIVING POSITION						
AIR CONDITIONING		○	○	○	○	○
DIGITAL INSTRUMENTS		●	●	●	●	●
WEIGHT AND DIMENSIONS (IN RUNNING ORDER)						
REAR TYRES (STANDARD)		12,4 R36	380/70 R28	12,4 R36	380/70 R28	12,4 R36
A - HEIGHT OVER CAB	MM	2438	2300	2438	2300	2438
B - WHEELBASE	MM	2162	2131	2162	2131	2162
C - OVERALL LENGTH WITH BALLAST WEIGHTS	MM	4020	3990	4020	3990	4020
D - MAX. GROUND CLEARANCE	MM	414	385	414	385	414
E - MINIMUM WIDTH	MM	1660	1722	1660	1722	1660
TOTAL WEIGHT WITHOUT BALLAST WEIGHTS (216KG)	KG	3050	2800	3050	2800	3050

Key: ● standard ○ option — not available
* Power estimated by manufacturer

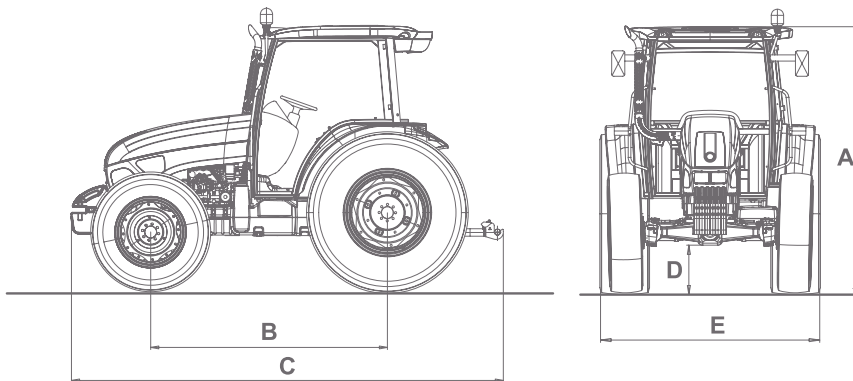

70-80-85 (T3)

CX-L

CX-L | CX-LC





CX-L and CX-LC (T3):
powerful, lightweight and versatile
to suit your **needs**



ENGINE

All models are equipped with the new, Tier 3 compliant, Yanmar 4TNV93 series naturally aspirated and turbocharged engines. With a total displacement of 3319 cm³ and powers of 69.5 - 76 - 81 hp (ISO), these direct-injection engines deliver superior performance in terms of horsepower, torque and torque backup. The forward tilting hood provides easy access to the engine for routine service and maintenance (*fig. A*).

FRONT AXLE

The four-wheel drive front axle allows a steering angle of 60° for maximum manoeuvrability.

To improve headland manoeuvring, especially when working between rows, McCormick has adopted the unique Fast-Run system (standard on the CX-LC model), featuring a wet multi-disc dual clutch. One clutch is used to engage the four-wheel drive, whilst the other allows the rotation speed of the front wheels to be increased by 78% when the steering angle exceeds 35°.

This decreases the steering time by 30%, while reducing the turning radius for better manoeuvrability and enhanced productivity (*fig. B*).



FRONT POWER LIFT AND FRONT PTO

The front power lift with Cat. 2 hitch provides the main raising/lowering and floating functions and ensures a maximum lift capacity of 900 kg.

The PTO with hydraulic engagement by pushbutton delivers a speed of 1000 rpm. The front power lift and PTO have been specially designed to enhance the versatility of the CX-L tractor range (*fig. B*).



TRANSMISSION

The POWER SHUTTLE transmission includes a SPEED FIVE base transmission, a CREEPER, a POWER FIVE transmission (electrohydraulically engaged HI-LO splitter gear activated by the green button allowing 20% speed reduction) (*fig. C*) and a REVERSE POWER SHUTTLE (hydraulic shuttle lever applied to the steering wheel) (*fig. D*) providing a total of 60 forward and 60 reverse speeds.

Combining the DE-CLUTCH CONTROL (orange pushbutton integrated in the gear lever for electrohydraulic engagement of the transmission clutch) (*fig. C*) with the REVERSE POWER SHUTTLE, this type of transmission allows all gears to be engaged and reversed without using the clutch pedal.







**McCormick CX-L and CX-LC (T3),
a great tractor
for small and medium sizes area**

HYDRAULICS

The hydraulic system provides a maximum total flow of 81 l/min and features four optional auxiliary valves to suit all kinds of application.

Easily accessible, high-quality quick-release couplings ensure optimum comfort of operation and improved tractor productivity (*fig. E*).



REAR POWER LIFT AND PTO

Optionally, the tractor can be equipped with an electronically-controlled power lift of latest generation. With the main controls rationally-arranged in ergonomic position on the console located to the driver's right (*fig. F*), the electronic power lift provides fingertip control of draft, position, intermix, float and sensitivity functions.

The heavy-duty Cat. II three-point hitch with two assistor rams features quick-release couplings and provides a lift capacity of 3400 kg (*fig. G*).

The PTO provides two speeds - 540/750 rpm (standard) or 540/1000 rpm (optional) - plus a ground speed for the use of trailers.

A multi-disc wet clutch operated by an electrohydraulic pushbutton integrated on the console to the driver's right enables smooth and progressive engagement of the PTO (*fig. F*).



CAB

The most outstanding feature of the CX-L tractor is the all-round visibility of the "DELUXE" cab provided by all-glass side doors hinged onto the rear post. Built using the modern composite materials of automotive design, the interiors are stylish and accurate and feature logically-arranged controls according to current ergonomic standards.

The adjustable seat, the new digital instrument panel and the steering wheel adjustable in height and inclination further improve the driving comfort.

The heating, ventilation and air-conditioning system installed on the cab roof offers the driver significant benefits in terms of comfort, safety and health. The roof features a fixed clear sunroof, ideal for work with front loaders, and four lights for night work. Natural ventilation is ensured by the openable front and rear windscreens (*fig. H*).

