

POWERFARM THE ESSENCE OF MODERNITY

The *Powerfarm Cab* and Platform tractor range features a clean and modern design. The new, environment-friendly *Perkins 1104D* series engines fitted on the *Powerfarm Cab* models offer high torque backup and improved fuel efficiency.

They meet the *Tier 3* emission standard and deliver 74, 83, 92.5 and 102 HP (ISO rating).

These engines feature an advanced fuel injection system that optimises air-fuel mixture, thereby improving combustion and engine efficiency.

The modular transmission provides, as standard, three ranges and four speeds in each range, resulting in a total of 12 forward and 12 reverse speeds with mechanical synchro shuttle.

The standard gearbox can be combined with either an *underdrive* (only for *2WD* versions) or a creep option to provide 24 forward and 12 reverse gears with a maximum speed of 30 km/h.

The height adjustable sprung seat and the hood with its rounded and plunging design provide excellent visibility when manoeuvring.

The tractor range comprises four models equipped with different engines and offers a choice of three transmissions and two cab styles for enhanced versatility, maximum comfort and increased productivity.



		POWERFARM 80 SYNCHRO SHUTTLE	POWERFARM 90 SYNCHRO SHUTTLE	POWERFARM 100 SYNCHRO SHUTTLE	POWERFARM 110 SYNCHRO SHUTTLE
ENGINE					
PERKINS TIER 3 DIRECT-INJECTION ENGINE		1104D-44	1104D-44T	1104D-44TA	1104D-44TA
MAX. POWER (ISO)	HP/KW	74/54,5	83/61	92,5/68	102/75
MAX. TORQUE	NM	261	352	363	416
DISPLACEMENT / NR. OF CYLINDERS	CM ³	4400/4	4400/4 TURBO	4400/4 TURBO AFTERCOOLER	4400/4 TURBO AFTERCOOLER
FUEL TANK CAPACITY	LT	102	102	102	102
CLUTCH					
INDEPENDENT DRY DUAL CLUTCH	IN.	11	11	12	12
MECHANICAL CONTROL		●	●	●	●
TRANSMISSION					
SYNCHRO SHUTTLE + SPEED FOUR: 12FWD+12REV (ONLY 2WD)		○	○	○	○
SYNCHRO SHUTTLE + SPEED FOUR + UNDERDRIVE: 24FWD+12REV (30 KM/H) (ONLY 2WD)		●	●	●	●
SYNCHRO SHUTTLE + SPEED FOUR + CREEPER: 24FWD+12REV (30 KM/H)		○	○	○	○
SYNCHRO SHUTTLE + SPEED FOUR + OVERDRIVE: 24FWD+12REV (40 KM/H)		●	●	●	●
ELECTROHYDRAULIC REAR DIFFERENTIAL LOCK (ONLY 2WD)		●	●	●	●
POWER TAKE-OFF					
MECHANICAL CONTROL		●	●	●	●
2 SPEEDS 540/750 RPM.		●	●	●	●
2 SPEEDS 540/1000 RPM		○	○	○	○
1"3/8 (34.9MM) PTO SHAFT WITH 6 SPLINES		●	●	●	●
GROUND SPEED PTO		●	●	●	●
NET PTO POWER (ISO)	HP/KW	63/46,5	70,5/52	79/58	86,5/63,5
FRONT 4WD AXLE					
MECHANICAL 4WD ENGAGEMENT		●	●	●	●
MAX. STEERING ANGLE		55°	55°	55°	55°
TWIN-LOCK ELECTROHYDRAULIC DIFF-LOCK		●	●	●	●
BRAKES					
GRAPHITE-COATED REAR WET BRAKES		10 DISCS	10 DISCS	10 DISCS	10 DISCS
GRAPHITE-COATED FRONT WET BRAKES - 4 DISCS		●	●	●	●
IBS - INTEGRAL BRAKING SYSTEM		●	●	●	●
HYDRAULIC HITCH					
DRAFT, POSITION, INTERMIX, FLOAT CONTROL FUNCTIONS		●	●	●	●
MECHANICAL CONTROL		●	●	●	●
STD LIFT CAPACITY	KG	2600	2600	2600	2600
LIFT CAPACITY WITH 2 AUXIL. CYLINDERS	KG	3700 ○	3700 ○	3700 ○	4350 ○
TOTAL HYDRAULIC FLOW	L/MIN	52,3+29,9	52,3+29,9	52,3+29,9	52,3+29,9
STD AUXILIARY VALVES		2	2	2	2
CAB AND DRIVING POSITION					
"TOTAL VIEW" CAB / RADIO ADAPTOR		●	●	●	●
AIR-CONDITIONING		○	○	○	○
ANALOG INSTRUMENT PANEL		●	●	●	●
DIMENSIONS IN RUNNING ORDER					
WITH TYRES		16.9-R30	18.4-R30	18.4-R30	18.4-R30
A - LENGTH (WITH BALLAST)	MM	4136	4136	4136	4160
B - MIN. WIDTH	MM	1945	2063	2063	2063
C - WHEELBASE 2WD/4WD	MM	2341/2316	2341/2316	2341/2316	2365/2340
D - HEIGHT OVER ROPS	MM	2510	2510	2550	2560
D - HEIGHT OVER CAB	MM	2518	2550	2550	2550
E - GROUND CLEARANCE 4WD	MM	425	453	453	453
WEIGHT 4WD (WITHOUT BALLAST) + (150KG CAB)	KG	3330	3330	3330	3450

Key: ● standard ○ option – not available

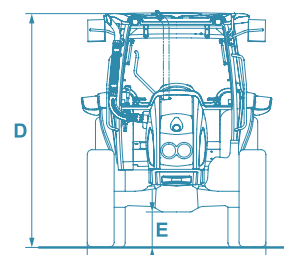
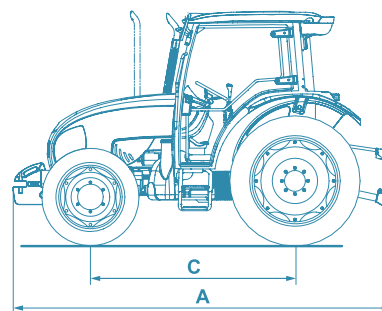
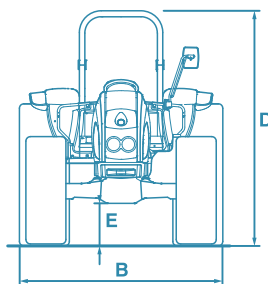
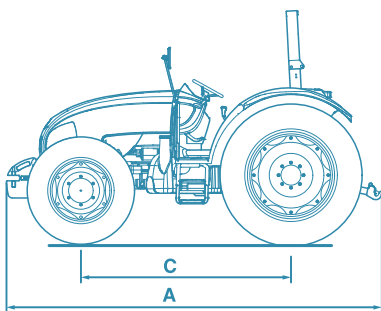

NEW

Powerfarm

80 - 90 - 100 - 110
SYNCHRO SHUTTLE



Landini®



LandArb®



NEW TIER 3 PERKINS 1104D SERIES ENGINES, MORE POWER WITH BETTER FUEL ECONOMY



THE *POWERFARM* TRACTORS ARE POWERED BY A NEW RANGE OF ADVANCED, ENVIRONMENT-FRIENDLY ENGINES THAT PROVIDE LOW EMISSION LEVELS IN ACCORDANCE WITH THE *TIER 3* STANDARDS. SPECIALLY DESIGNED FOR FARMING APPLICATIONS, THE NEW *PERKINS 1104D* ARE MODERN ENGINES THAT PROVIDE STATE-OF-THE-ART TECHNOLOGY AND SOLUTIONS. THE RANGE COMPRISES FOUR MODELS DELIVERING THE FOLLOWING POWER RATINGS: 74 HP (NATURALLY ASPIRATED), 83 HP (TURBO), 92.5 AND 102 HP (TURBO AFTERCOOLED). THESE ENGINES FEATURE AN ADVANCED FUEL INJECTION SYSTEM THAT OPTIMISES AIR-FUEL MIXTURE, THEREBY IMPROVING COMBUSTION AND ENGINE EFFICIENCY. HIGHER HORSEPOWER AND TORQUE WITH LOWER OPERATING COSTS ARE THUS ACHIEVED. THE FORWARD TILTING HOOD PROVIDES EASY ACCESS TO THE ENGINE COMPARTMENT FOR ROUTINE SERVICE AND MAINTENANCE. > FIG. A

LATEST-GENERATION FRONT AXLE

THE FOUR-WHEEL DRIVE FRONT AXLE WITH 55° STEERING ANGLE FEATURES WET DISC BRAKES. THE COMBINED ACTION OF FRONT AND REAR BRAKES ENSURES SAFE, EFFECTIVE BRAKING ON ALL FOUR WHEELS . > FIG. B

MODULAR SPEED FOUR TRANSMISSION

THE MODULAR STANDARD TRANSMISSION (*SPEED FOUR*) PROVIDES 3 RANGES AND 4 SPEEDS IN EACH RANGE, RESULTING IN A TOTAL OF 12 FORWARD AND 12 REVERSE SPEEDS WITH MECHANICAL SYNCHRO SHUTTLE. THE STANDARD GEARBOX CAN BE COMBINED WITH EITHER AN UNDERDRIVE (ONLY FOR 2WD VERSIONS) OR A CREEP OPTION TO PROVIDE 24 FORWARD AND 12 REVERSE GEARS WITH A MAXIMUM SPEED OF 30 KM/H. AN OVERDRIVE OPTION IS ALSO AVAILABLE FOR 4WD MODELS TO PROVIDE 24/12 GEARS WITH 40 KM/H MAXIMUM SPEED. THE SYNCHRO SHUTTLE LEVER IS CONVENIENTLY LOCATED TO THE DRIVER'S LEFT TO ENABLE EASY DIRECTION CHANGES. THE SAME LEVER CAN BE USED TO ALTERNATELY ENGAGE THE UNDERDRIVE, CREEP OR OVERDRIVE OPTION. > FIG. C-D

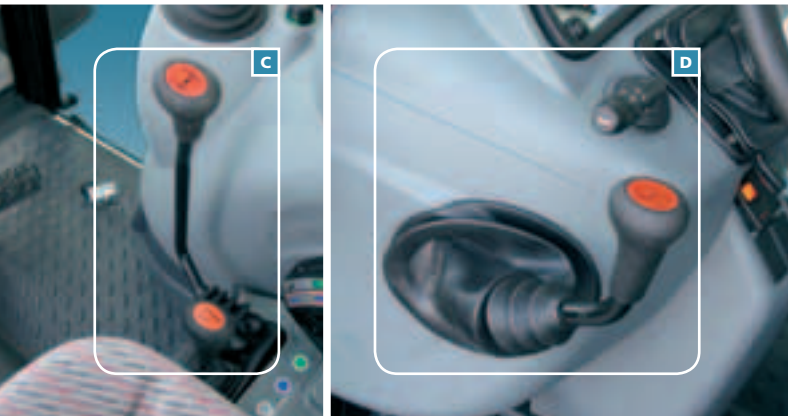

ANALOG INSTRUMENT PANEL

AN EASY-TO-READ ANALOG INSTRUMENT PANEL KEEPS THE OPERATOR CONSTANTLY INFORMED OF THE TRACTOR PERFORMANCE AND CONDITIONS.





COMFORT AND ERGONOMICS,



A WINNING COMBINATION



HIGH-PERFORMANCE HYDRAULICS FOR HITCH AND REMOTE VALVES

THE MECHANICAL HITCH PROVIDES A MAXIMUM TOTAL FLOW OF 82 LITRES/MIN.

THE HITCH, EQUIPPED WITH A CAT. 2 THREE-POINT LINKAGE, PROVIDES POSITION, DRAFT, INTERMIX AND FLOAT CONTROL FUNCTIONS AND ENSURES A MAXIMUM LIFT CAPACITY OF 4350 KG. > FIG. F-H

THE SYSTEM FEATURES UP TO 4 REMOTE VALVES, TWO OF WHICH CONTROLLED BY JOYSTICK FOR FRONT LOADER WORK, [> FIG. G] AND TWO CONTROLLED BY STANDARD LEVERS CONVENIENTLY LOCATED BESIDE THE DRIVER'S SEAT. > FIG. F



"TOTAL VIEW" CAB FOR ALL-ROUND VISIBILITY

THE FIRST THING YOU APPRECIATE WHEN YOU STEP INTO THE "TOTAL VIEW" CAB IS THE SUPERB ALL-ROUND VISIBILITY OFFERED BY THE FULLY-GLAZED REAR-HINGED SIDE DOORS.

THE CAB INTERIOR IS FINISHED WITH MODERN COMPOSITE MATERIALS FROM THE AUTOMOTIVE INDUSTRY.

ALL CONTROLS ARE LOGICALLY-ARRANGED AND CONVENIENTLY-LOCATED ACCORDING TO THE LATEST ERGONOMIC STANDARDS.

THE HEATING, VENTILATION AND AIR-CONDITIONING SYSTEM, INTEGRATED INTO THE CAB ROOF, OFFERS THE DRIVER SIGNIFICANT BENEFITS IN TERMS OF COMFORT, SAFETY AND HEALTH.

THE VENTILATION SYSTEM IS INTEGRATED BY TWO FILTERS DESIGNED TO PURIFY THE AIR INSIDE THE CAB. OPTIONALLY, THE CAB CAN BE PROVIDED WITH ACTIVATED-CARBON FILTERS, TO PROTECT THE OPERATOR DURING PESTICIDE SPRAYING.

THE ROOF FEATURES A FIXED CLEAR SUNROOF FOR WORKING WITH FRONT LOADERS, AND FOUR LIGHTS FOR NIGHT WORK. NATURAL VENTILATION IS ENSURED BY THE OPENING FRONT AND REAR WINDSCREENS.> FIG. I

ALSO THE ISO-MOUNTED PLATFORM OFFERS AN ERGONOMIC DRIVING POSITION WITH ADJUSTABLE MAXIMISE THE DRIVER'S COMFORT.

THE TWO-POST ROPS CAN BE EQUIPPED WITH A SUN CANOPY AS AN OPTION.

