

AXION
850 840 820 810
AXION CMATIC
840 820 810

CLAAS

Top performance with
minimal fuel
consumption.





AXION

CLAAS

AXION
840



Profitability counts.

As a leading producer of agricultural machinery, CLAAS is uniquely placed to work out what really matters to the farming community. Outstanding versatility, the greatest possible comfort, intelligent technology and above all value for money - these are the factors that count.

Time and again, in all of these areas, CLAAS has set new standards and developed new solutions to make your work easier, and will continue to do so in future. The AXION is the perfect example of this – a tractor with impressive performance features and characteristics. Available with the option of CMATIC, the infinitely variable transmission model, giving you impressively high standards of comfort. All the AXION components are perfectly coordinated to enable you to work efficiently and, most importantly, cost-effectively. High performance with minimal fuel consumption.

The AXION from CLAAS.
Now with infinitely variable
transmission.





The comfort features.

Everything is straightforward, functional and ergonomically designed in the only 4-point full-suspension cab on the market. The multifunction armrest with DRIVESTICK and the CEBIS terminal allow all functions to be easily controlled by the driver from the comfort of the cab. Perfect sound insulation, intuitive light control and automatic air conditioning ensure an ideal work environment.

Versatility

The name AXION represents a tractor concept which is not limited to a single application, such as field work or road travel. The optimum wheelbase of 2.98 metres, the minimum overall length and the freely selectable ballasting of up to 2.9 tonnes make a significant contribution. In addition, there is the enormous lift capacity, together with CLAAS performance data never witnessed before: 600 rpm constant power range, 43% torque increase and up to 35 hp additional power reserve.

Intelligence

A tractor on its own is not much use – only in combination with implements can you use the AXION to its full potential, thanks to intelligent, advanced technology – no matter whether for baling, mowing, ploughing, stubble tillage, sowing or transport.

Some things will be different –
and many things will be easier.





Value for money

Profit from fuel-saving boost technology – where others guzzle fuel, the engine takes only what it needs for the actual output performed. You'll also benefit from engine technology that meets optimum efficiency requirements. Additionally, automatic devices help to optimise the working speed. This means the engine remains economical, because it always operates in the ideal speed range.

Contents

Configuration variants	8
Comfort concept	10
Armrest and DRIVESTICK	12
CEBIS tractor control terminal	14
CLAAS INFORMATION SYSTEM	16
CIS	
Suspension and lighting concept	18
Versatility	20
Drives	22
Output and dimensions	24
Power-to-weight ratio	26
Engines	28
Transmission options	30
Intelligence	38
Front linkage, rear linkage	41
Hydraulics, hitching, power take-off	42
CSM, ISOBUS	44
GPS PILOT, CAM PILOT	46
Economic efficiency	48
Saving fuel	50
Lowering maintenance costs	52
Increasing productivity	54
Ensuring reliability in the field	56
Specifications	58



Always geared for action.

CLAAS caters to a wide variety of customer requirements with three configuration variants to choose from: CIS, CEBIS and CMATIC, enabling users to select the tractor that is right for them, together with additional equipment specifications as required.

CIS configuration.

The CIS configuration delivers the highest degree of comfort with cab suspension and multifunction armrest as well as unparalleled output, thanks to the boosting function of the CPM (CLAAS POWER MANAGEMENT) and HEXASHIFT transmissions. Additionally, the CIS (CLAAS INFORMATION SYSTEM) facilitates configuration of the HEXACTIVE automated gear-shifting system, as well as the electronic spool valves of the ELECTROPILOT.

CEBIS configuration.

The CEBIS configuration is recommended where the AXION is used intensively for drilling, mowing or for contract work. In addition to the features provided by the CIS configuration, CEBIS with its colour-coded terminal provides full control of additional functions, including time and flow regulation for up to eight spool valves, CSM (CLAAS SEQUENCE MANAGEMENT) headland management, and also device and field management.

AXION as you need it.



CMATIC configuration.

AXION CMATIC expands on the CEBIS configuration and features an infinitely variable transmission to facilitate greater precision when modifying vehicle speed, ensuring a minimum speed of 50 m/h at rated engine speed. This enables the AXION CMATIC to deliver peak driving comfort, especially during baling or on the road.



Configuration variants

Comfort is so much more than just a comfortable seat.

The AXION contributes everything to significantly ease your working life and help you approach jobs in a more effective and relaxed manner – even if, on occasion, you are confronted with larger or more complex tasks. This means you can feel good on board and your health is protected.

For the perfect overview: the CEBIS terminal

Everything to hand first time:
the multifunction armrest with DRIVESTICK

Comfortable even with implements:
oscillation dampening of front and rear linkages

Groundbreaking:
the sprung front axle for greater comfort

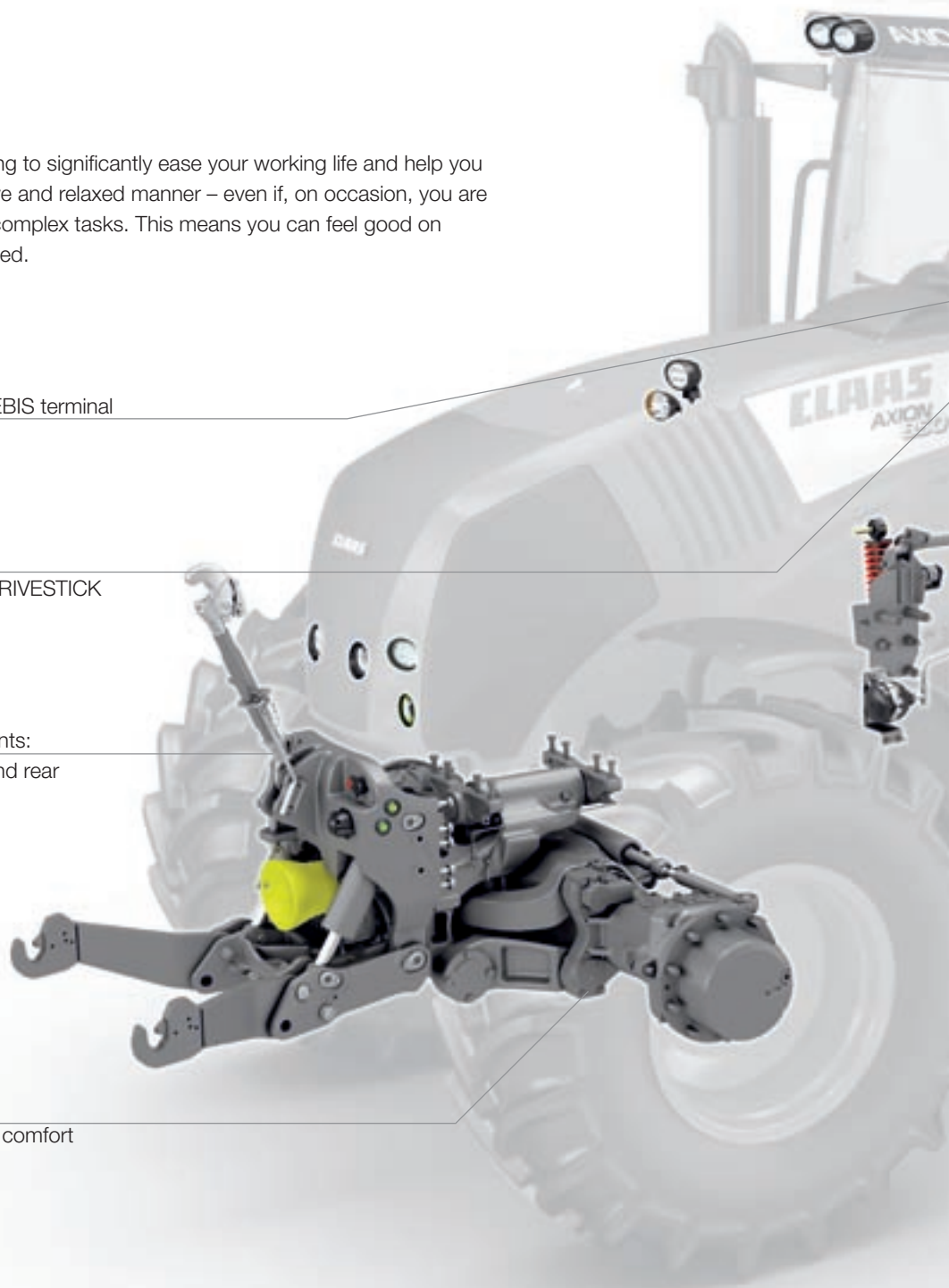



Always keeping cool:
the automatic climate control

A further highlight:
the lighting concept with intuitive
operation. Up to 14 work lights and four
additional Xenon headlights.

A good place to work from:
the pneumatically sprung
low-frequency seat

Unique in the market:
the cab with four-point full suspension

The optimum wheelbase of 2.98 m:
for stable straight running
and great comfort

Control at your fingertips.



The unique DRIVESTICK.

The DRIVESTICK is used intuitively, and gives you full control via the HEXASHIFT or CMATIC transmission. Complex and cumbersome shifting operations therefore become a thing of the past. All you need is to develop the right feel for the DRIVESTICK's operation to shift as you please.

The CMATIC transmission is also operated using the DRIVESTICK:

- The cruise control is actuated via the orange button
- DRIVESTICK mode: acceleration and deceleration by changing the engine speed and gear
- MANUAL mode: only the transmission ratio is changed, while the engine speed is controlled via the accelerator

The perfectly ergonomic armrest.

The multifunction armrest has been designed for optimum ergonomics, and is the linchpin to relaxed and effective working. It's the result of extensive analyses of the operating processes in the cab: frequently required functions are located on the multifunction armrest, while those required less frequently are located on the right side console.

- Shifting operation Powershift +/-
- Shifting operation Range +/-
- Skipshift function





- 1 Controls for the rear linkage and CSM headland management
- 2 DRIVESTICK for operating the HEXASHIFT or CMATIC transmission
- 3 Hand throttle
- 4 Activation of HEXACTIV automatic transmission and push switch for two stored engine speeds
- 5 ELECTROPILOT for proportional operation of up to five electronic spool valves
- 6 F1 and F2 function, e.g. for direct access to the task management
- 7 Changes the ELECTROPILOT spool valve configuration
- 8 Comfortable and proportional operation of up to three electronic spool valves
- 9 Rear linkage depth adjustment

The benefits for you:

- Intuitive operation, even with different drivers
- You stay relaxed and work effectively
- You manage work sequences in simple steps
- Full concentration on the field work
- A relaxed hand position, even during long working days
- No relative movement between body and armrest, since it is fastened to the seat



Armrest and DRIVESTICK



With the AXION fitted with CEBIS, you can experience the premium-class technology which has proven its worth time and again in the LEXION and XERION top-of-the-line machine ranges. This technically advanced tractor terminal gives you complete control of all machine functions by means of a large, easy-to-read display and simple operations via a control knob.

CEBIS on the road.

- 1 Menu bar
- 2 Ground speed and rpm
- 3 User-defined information
- 4 Detailed assignment of function buttons
- 5 Status display, transmission and direction of travel
- 6 Vehicle status information
- 7 Fuel and temperature display

CEBIS in the field.

- 8 Expanded transmission display
- 9 Detailed view of working parameters
- 10 Status display, front and rear linkages
- 11 Spool valve settings status

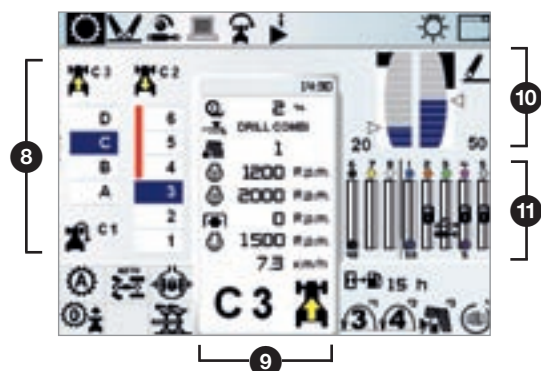
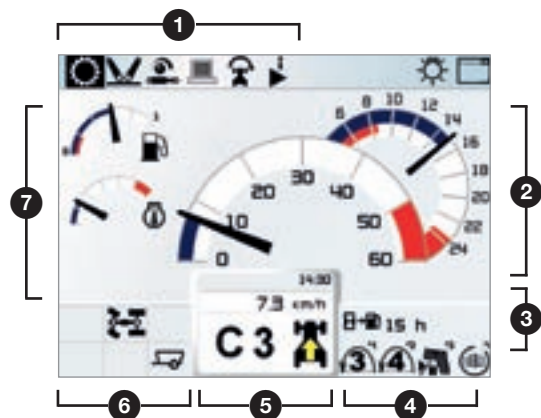

Once you're familiar with CEBIS, you won't want to do without it.



What makes CEBIS different from other tractor terminals:

- Only two operating elements: "control knob" and "ESC"
- Quick access to sub-menus through DIRECT ACCESS
- Integrated built-in performance monitor as standard for checking area output, fuel consumption, job data
- Two different screen layouts to choose from as standard (road travel and field work)

The benefits for you:

- You're always fully in the picture regarding all relevant processes with the actual status
- It's easy to operate and intuitive to use
- You leave nothing to chance, because you always know what's going on
- You can concentrate more on the field work, because CEBIS automatically does the routine tasks

CEBIS quick access with DIRECT ACCESS.



Actuating the function

DIRECT ACCESS

Changing the settings directly in the submenu

CEBIS tractor control terminal



The CLAAS INFORMATION SYSTEM CIS always keeps you up to date:

When the AXION is controlled by mechanical spool valves instead of the CEBIS terminal, the CIS (CLAAS INFORMATION SYSTEM) in the dashboard replaces the CEBIS.

AXION	CIS	CEBIS
Multifunction armrest	•	•
DRIVESTICK	•	•
PTO shaft management	•	•
Mechanical control valves	•	–
CIS display	•	–
Electronic control valves	–	•
CEBIS terminal	–	•
Headland management CSM	–	•
Engine speed memory	•	•
ELECTROPILOT	•	•

● Standard ○ Optional – Not available

With its compact design, the CIS display provides the same user ergonomics as the CEBIS terminal: all settings can be operated using a control knob and the "ESC" key.

The following functions can be set using the CIS:

- HEXACTIV power shift unit switching points
- HEXASHIFT transmission start ratio
- REVERSHIFT aggressivity of the clutchless reverser
- Time and volume settings for the electronic spool valves on the ELECTROPILOT (optional)
- Performance monitor functions, such as finished surface area, fuel consumption, work rate
- Display of the maintenance intervals

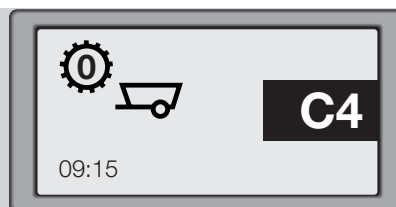
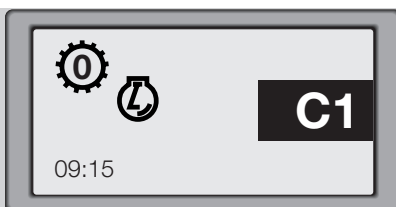
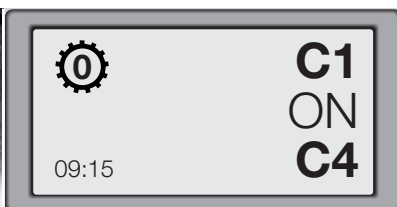

Mechanical spool valves will also keep you fully informed – thanks to CIS.



The advantages of models with CIS display and mechanical spool valves:

- All information in view via A-pillar display and CIS
- Steering column with self-cancelling indicators
- Fitted with multifunction armrest and DRIVESTICK for transmission operation as standard
- Up to four mechanical spool valves with float setting
- Simple to operate, even with different drivers



Example of setting the starting gear of the transmission with the CIS display.

CLAAS INFORMATION
SYSTEM CIS

Nothing can shake an AXION driver.

No matter how rough the terrain, the AXION ensures that you won't feel a thing – because it's the only one in this performance range with a 4-point fully suspended cab. But this is just one example of a suspension concept which can be commended in every aspect.

- The driver's seat is pneumatically suspended and supports your back – even during longer sessions
- The sprung front axle absorbs vibrations right from the outset
- Front and rear linkages are vibration-damped

The new lighting concept turns night into day.

Up to 14 work lamps (of which four Xenon headlights are available as an option) ensure that every nook and cranny will be perfectly illuminated. That means you can decide quickly and individually where to shine a light.

Advantages with AXION comfort:

- Relaxed and motivated drivers
- Higher speed, thanks to cab suspension
- Back and muscles are significantly relieved
- Good productivity, by day, in the evening and at night
- Avoidance of operating errors, thanks to logical control layout



Safe and convenient access to the cab, thanks to convenient placement of steps and handles.





Suspended front axle.

A parallel linkage guarantees high driving comfort with the heaviest loads and, at the same time, increased tractive force. The necessary maintenance is limited to three grease nipples, which are accessible from above.



The 4-point cab suspension.

The cab suspension makes a crucial difference: vertical and horizontal vibration is effectively absorbed at four points. This full suspension system is exclusively offered by CLAAS, so that nothing will compromise your driving enjoyment.

MP3 radio with Bluetooth function.



Suspension and lighting concept

The new formula for versatility: ideal working weight and more hp.

Additional 35 hp with the boost of the
CLAAS POWER MANAGEMENT with

- Transmissions in range C or D (from approx. 6 km/h)
- Hydraulic output supply
- PTO shaft output supply

Large performance range of the 6.8-l, six-cylinder
engines from DPS with a power rating of 163 to
225 hp (in accordance with ECE R 24)

The ideal combination:

a long wheelbase with a short overall length, even
with front linkage and front power take-off

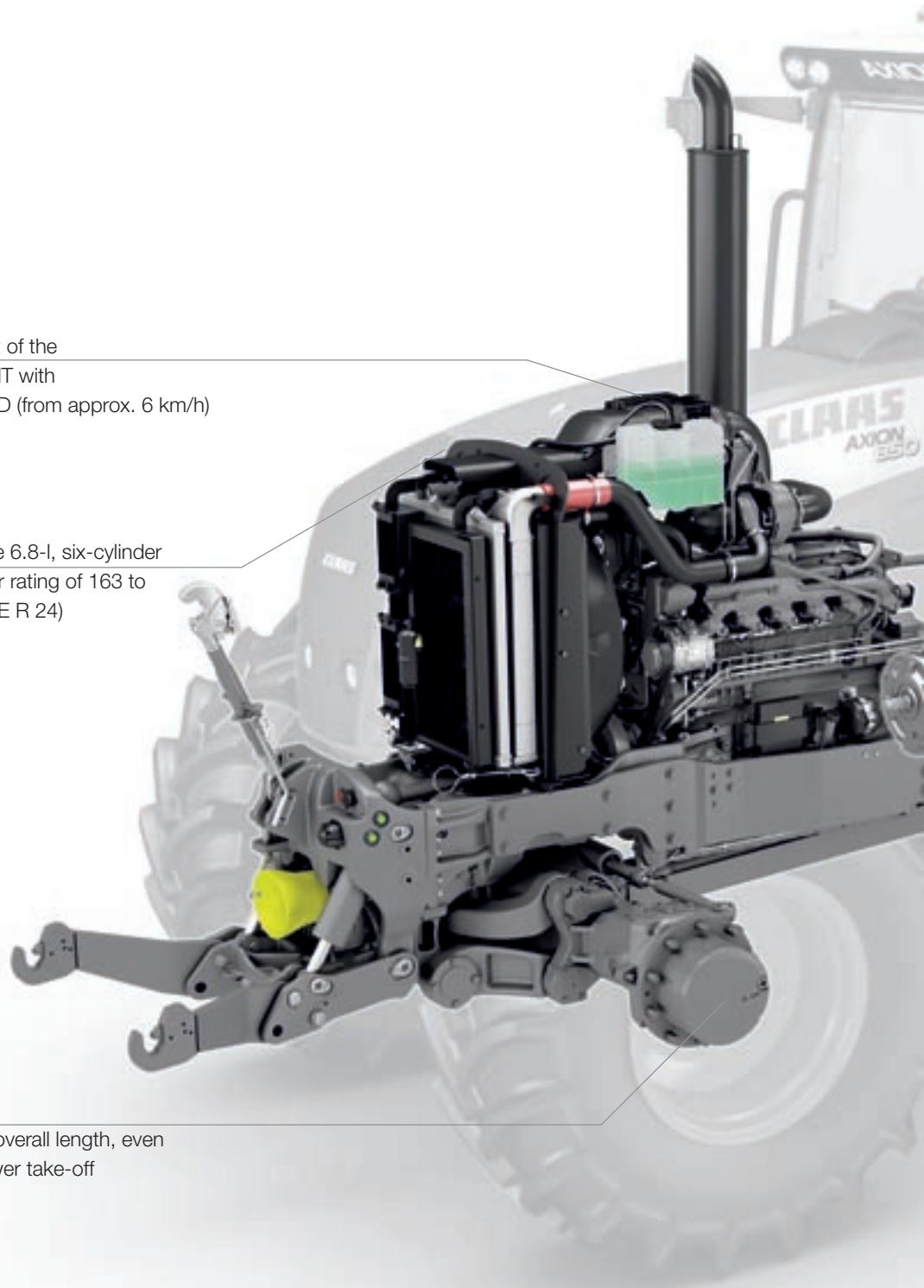

CPS | CLAAS
POWER
SYSTEMS

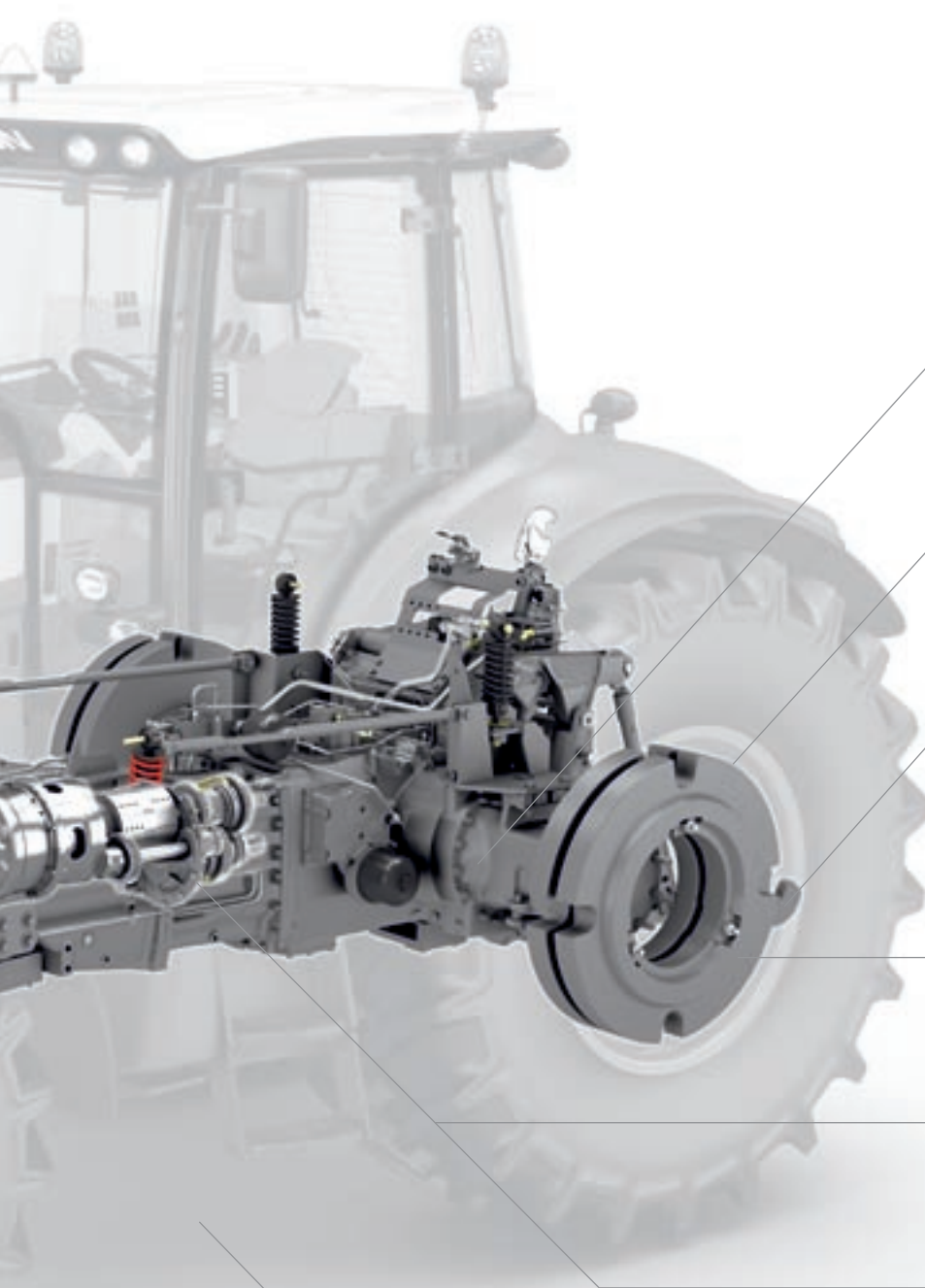

Heavy-duty rear axle perfected to combine high carrying capacity with low drive-train power loss

A high load capacity of up to 6.5 t, also for heavy implements

High linkage lift capacity of more than 10 t in the rear linkage and more than 5 t in the front linkage, even with the heaviest implements

Up to 700 kg wheel weight per rear wheel for heavy pulling operations

From 400 m/h (with creeper gear as an option) to 50 km/h with HEXASHIFT transmission

Infinitely variable 50 m/h to 50 km/h with CMATIC transmission

Low power-to-weight ratio from 33 kg/hp (45 kg/kW) for low fuel consumption with partial load operations



CPS: optimal drive for best results.

At CLAAS, machine development means an ongoing effort to achieve even greater efficiency and reliability as well as optimal profitability in the field. The CLAAS AXION 800 series is no exception; the entire drive train is of the utmost importance and encompasses much more than just a powerful engine.

In CLAAS POWER SYSTEMS (CPS), we have brought together top-quality components to create a drive system that is in a class of its own – one that always delivers the most efficient power when needed. CPS is ideally matched to the working system, featuring fuel-saving technology that quickly pays for itself. Power equals efficiency.

CPS | CLAAS
POWER
SYSTEMS

Get more done.

Electronics for improved performance.

In order to increase the mechanical efficiency of the AXION still further, CLAAS engineers have developed an integral electronic control system designed to get the best out of each component. The transmission control, for instance, is adapted to the current engine output in order to make gear shifting even smoother and more precise.

Systems such as CPM, HEXASHIFT, HEXACTIV, CMATIC, CSM, and also rear linkage slip control, push the bounds of efficiency and intelligent performance even further.

Profi Test (12/08) evaluation:

"In Powermix testing, the Axion 850 proved to be far more economical than the average tractor in almost every type of work. The overall Powermix result is a good 7% better than the average of all test subjects rated to date."

The AXION 850 was tested by the independent testing agency of the German Agricultural Society (DLG). The tests measured the tractor's engine and tractive power.



A unique combination of compact size and power.

Short overall length



Long wheelbase of 2.98 m

The perfect combination.
A short overall length for:

- Good manoeuvrability
- Short trailer combination on the road
- Good visibility
- Good guidance of front attachment devices

Long wheelbase for:

- High level of driving comfort
- Directional stability
- Higher tractive power, thanks to better weight distribution
- Good and secure road holding
- Higher lifting power, thanks to better weight distribution





Up to 260 hp with boost

Wide area of application.

Up to 260 hp usable engine output:

- From 6 km/h during tillage
- During sowing – heavy PTO work
- During trailer and transport jobs
- During baling

A low power-to-weight ratio:

- For low fuel consumption during light work
- For low ground pressure during field maintenance
- For dynamic road transport
- The weight-to-power ratio can be increased through ballasting if higher traction is required.
- For a high permissible load capacity
- Weight distribution with front ballasting front/rear 52% / 48%



Power-to-weight ratio from only 33 kg/hp (45 kg/kW)



Output and dimensions



Make use of the tractive power built into the AXION:

- Rear axle tyres up to 2.05 m in diameter
- Up to 700 kg wheel weight per rear wheel
- Configured for dual wheels at the factory (dual wheels only available on front axle on AXION 840/850 with unsuspended front axle)
- High chassis efficiency with careful matching of transmission and rear axle
- Good weight distribution with a long wheelbase
- Front ballast up to 1.5 t ex factory

A tractor can never apply a tractive force in excess of its weight. By means of ballasting, however, the AXION can achieve even more during pulling operations¹.

Make your road travel and maintenance operations more economical:

- 50 km/h max. speed as an option (not available in every country)
- High transmission efficiency
- Low fuel consumption, even with partial loads
- High driving comfort
- Reduced engine speed at 40 km/h and 50 km/h with HEXASHIFT and also with the CMATIC transmission
- Power-to-weight ratio from 33 kg/hp (45 kg/kW)

¹ Background: owing to the friction between the tyres and the ground, only a specific part of the intrinsic mass of a tractor can be converted into traction.

The higher the mass of a tractor, the more traction can be applied.

You decide on the ideal operational weight.



Power-to-weight ratio

A lot of power under the bonnet – and 35 hp in reserve.

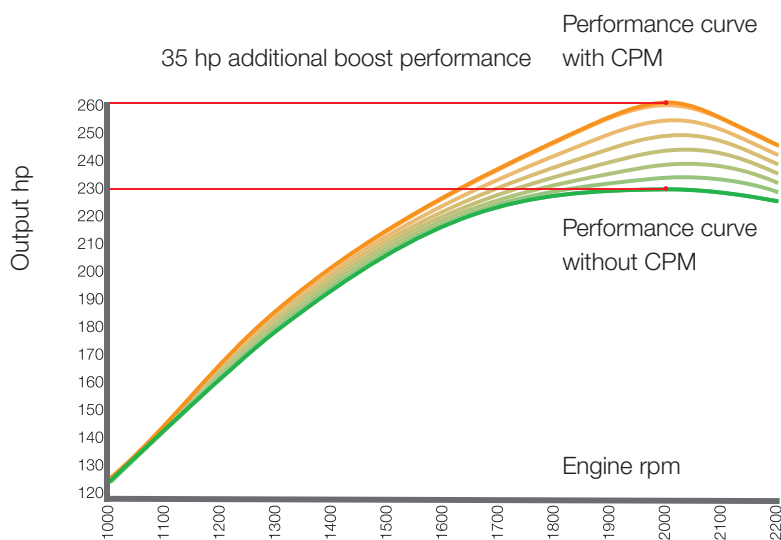

CLAAS POWER MANAGEMENT CPM

All AXION models are fitted with the innovative CPM. Depending on the tractive power requirement, PTO shaft output or hydraulic power decrease, up to 35 hp additional engine performance will be gradually released under the following conditions:

For the HEXASHIFT model:

- Transmissions in range C or D (C1 = 6 km/h)
- Load on hydraulics
- Load on PTO

For the CMATIC model:

- Ground speed over 7 km/h
- If hydraulic output is decreasing
- Load on PTO

Here, the additional boost performance is released by the CPM in six steps. That way, no more fuel-consuming output is released than is actually required.

Examples of use where the 35 hp of the CPM are available:

- Medium and light cultivating
- Sowing
- Baling
- Slurry application
- Slow field transport and fast road travel

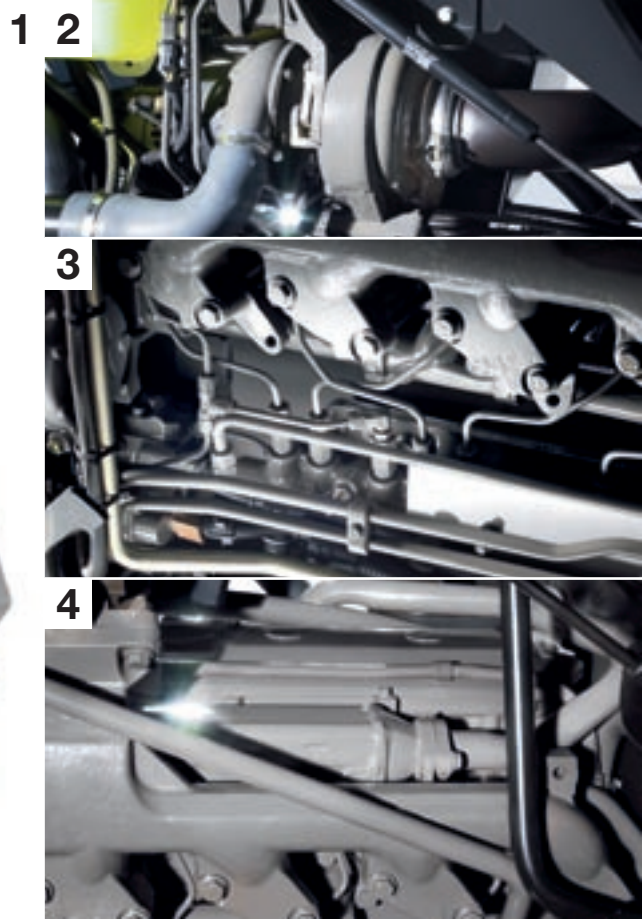
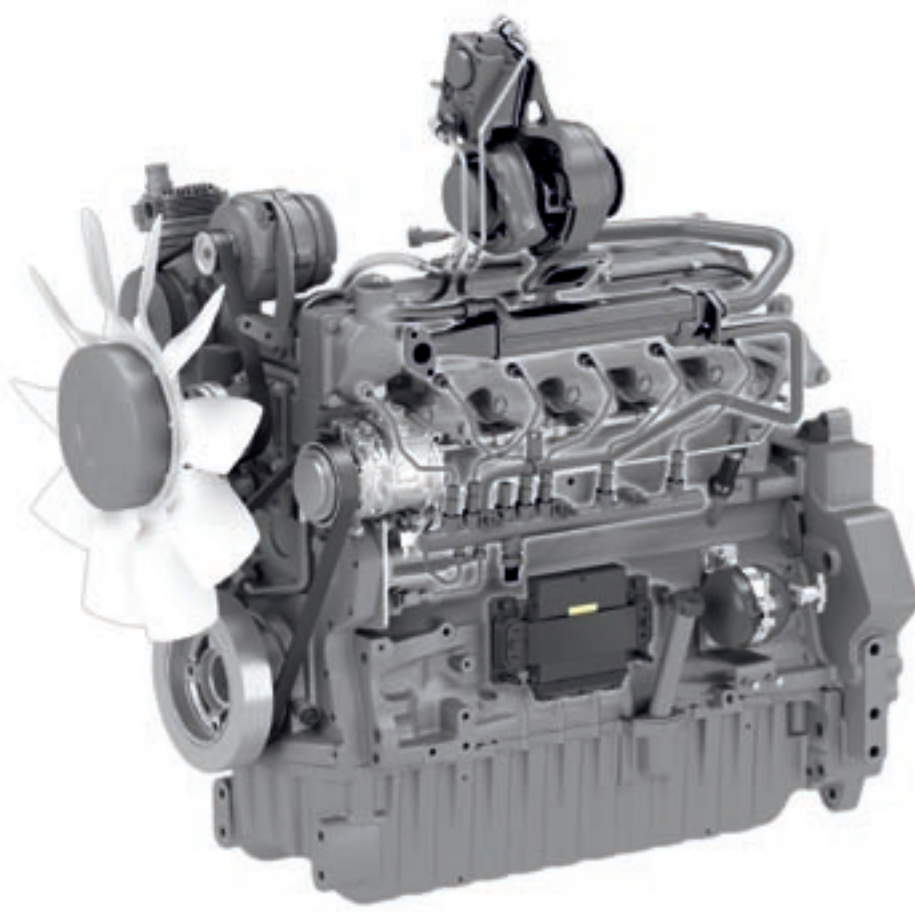

1 DPS 6.8-l six-cylinder engine.

- Meets TIER-3 emissions standard
- 4-valve cylinder head
- Air-to-air intercooler
- Up to 43% torque increase
- Modern CPM boost technology
- Up to 13 hp reserve power
- Electronically controlled
- 500-h oil-change interval

Output values in accordance with ECE R 24.

AXION	Rated output 2,200 rpm	Max. ~1,800 rpm	Boost 2,000 rpm
850	225	238	260
840	205	213	240
820	189	193	227
810	170	180	214

2 Turbo with variable geometry (VGT).

For a high torque, even at low engine speeds, the turbine blades are adjusted depending on speed and load. This means no more "turbo lag".

3 Common rail injection system.

Common rail means improved response, lower fuel consumption and a more precise engine matching to all operating states.

4 Cooled exhaust gas recirculation.

The recirculation of part of the exhaust gas flow significantly reduces pollutant emissions. Supplementary cooling optimises the combustion process and reduces consumption.

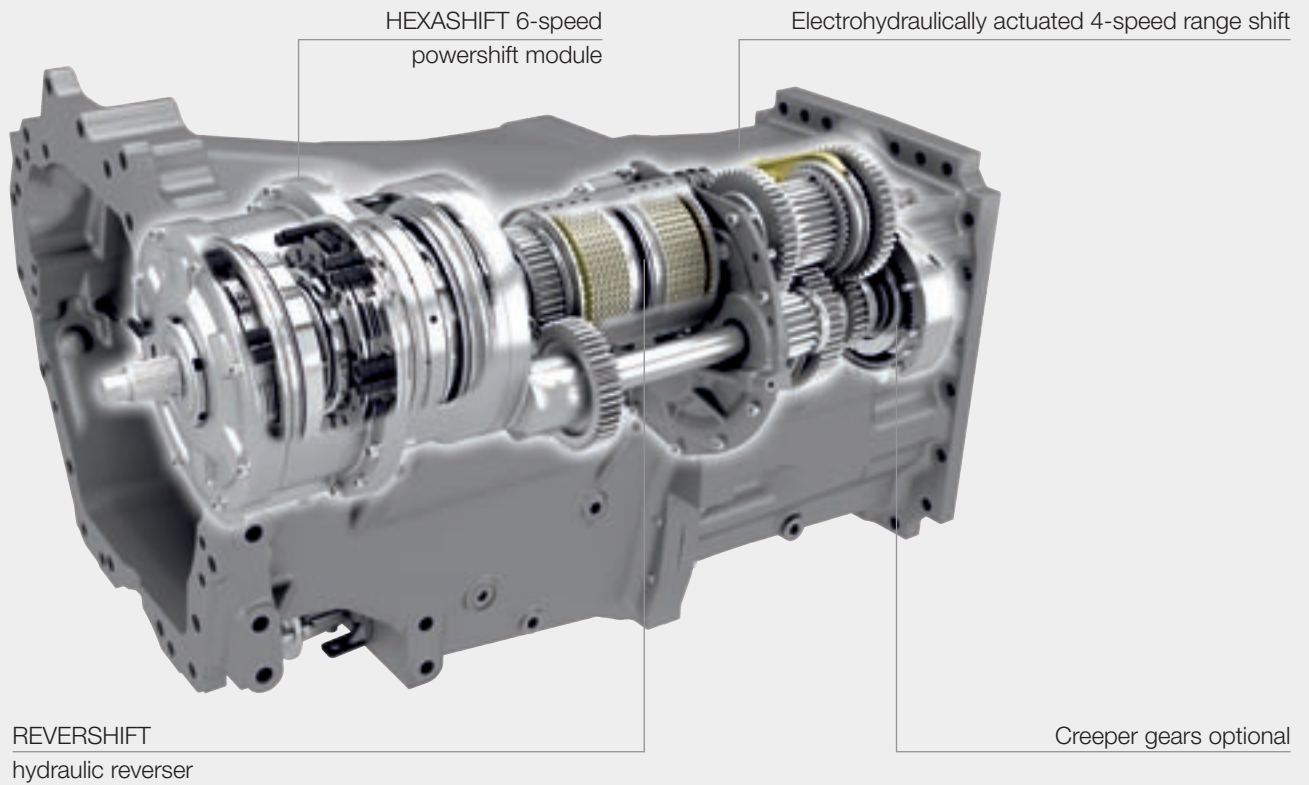

The HEXASHIFT automated transmission from CLAAS.

It supports you with the best high technology. Thanks to HEXASHIFT and the DRIVESTICK, you can easily shift between the six powershift ratios and the four ranges with your fingertips, or shift automatically with the HEXACTIV powershift unit.

CLAAS HEXASHIFT offers clear benefits.

- No more range shifting with the clutch
- Good gear shifting in the main working range
- Fully automatic shifting operation with HEXACTIV power shift unit
- Good efficiency in the field and on the road for low fuel consumption
- Creeper gear option down to 400 m/h
- Comfortable adjustment options with CEBIS or CIS
- High operating comfort with the DRIVESTICK
- Power train management for smooth changes in range and powershift operations

The perfect speed automatically – no matter what you're doing.



Always the right speed.

Regardless of whether you choose the 40-km/h or the 50-km/h transmission model, the gear spacing in the lower ranges A to C remains the same. This means that, when working in the field, you will always have enough ratios to choose from in the main working range.

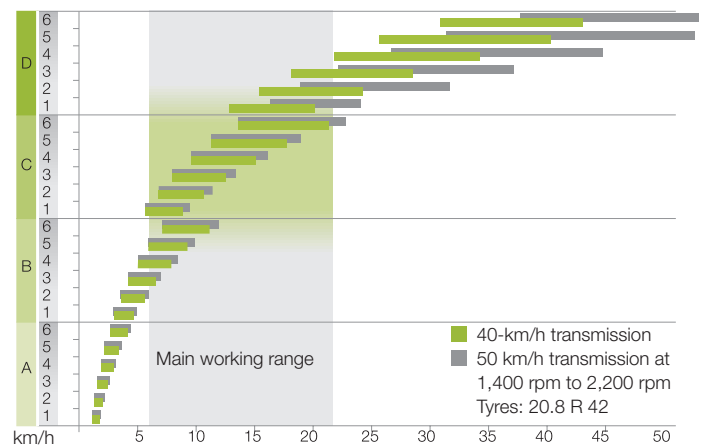

Almost everything is in the green zone – 80% of all agricultural operations can be carried out without changing the range.

Transmission options

Let the AXION do the shifting – you've got better things to do.



The attractive new HEXASHIFT features in the AXION.

- 1 The starting ratio can be individually set via the CEBIS or CIS terminal.
- 2 Infinitely variable adjustment of the shift points for the automatic powershift unit via CEBIS and CIS.
- 3 The modulation of the REVERSHIFT reverser can be changed in the CEBIS or CIS menu.



- 4 A freely programmable headland gear is actuated by pushing the DRIVESTICK.





Four driving strategies.

1 Manual shifting in field mode

Mode

- Field mode selected
- HEXACTIV switch not pressed

Switching

- Range shifting by pressing the DRIVESTICK through the stop
- Powershift shifting (1–6) by tapping the DRIVESTICK



2 Manual shifting in transport mode

- Road mode selected
- HEXACTIV switch not pressed

- Range shifting by tapping the DRIVESTICK
- Powershift shifting (1–6) by tapping the DRIVESTICK



3 Automatic shifting in field mode

- Field mode selected
- HEXACTIV switch pressed

- Range shifting by pressing the DRIVESTICK through the stop
- Powershift shifting (1–6) automatic



4 Automatic shifting in transport mode

- Road mode selected
- HEXACTIV switch pressed

- Range shifting automatic
- Powershift shifting (1–6) automatic

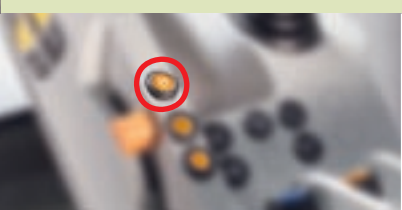

Transmission options

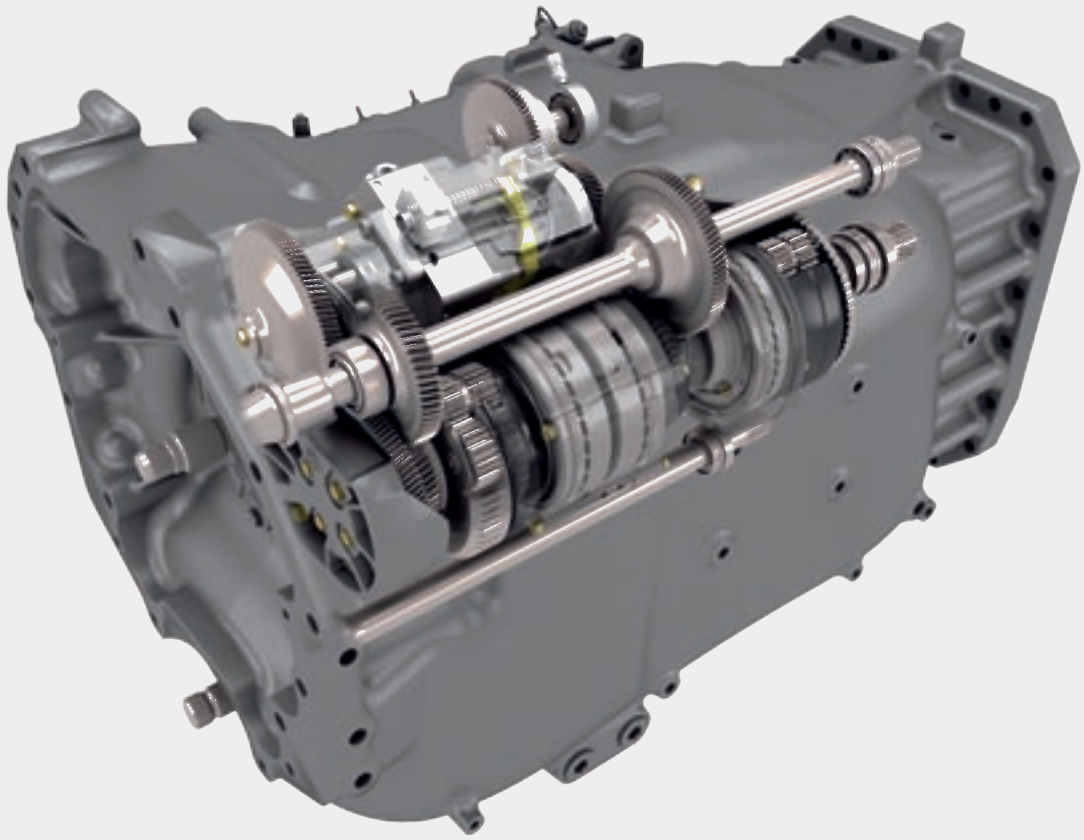

CMATIC: the most comfortable transmission model from CLAAS.

The continuously variable CMATIC transmission provides unique driving comfort: by simply pushing the accelerator pedal, the ground speed is varied. Engine speed and transmission ratio are automatically adjusted to bring out the best in the AXION – with the lowest fuel consumption.



Accurate in the field, economical on the road and always top driving comfort.

Advantages of CLAAS CMATIC:

- Fully automatic engine/transmission management
- The ratio is automatically chosen to keep fuel consumption at a minimum
- High effectiveness of the transmission, because only a small portion of the power is transmitted hydrostatically
- Powered zero very convenient, since the AXION stops without actuating the brakes, even on slopes
- Minimum speed 50 m/h at a nominal engine speed for slowest ground speeds
- Comfortable transmission adjustment via CEBIS
- High driving comfort, thanks to DRIVESTICK actuation
- The continuously variable CMATIC transmission always provides the right ground speed, no matter what the work



Transmission options



The attractive CMATIC features in the AXION with infinitely variable transmission.

- 1 Setting the cruise control speeds and maximum speeds forwards and backwards with CEBIS
- 2 Setting of acceleration and engine power drop
- 3 Well-laid-out display of all important functions

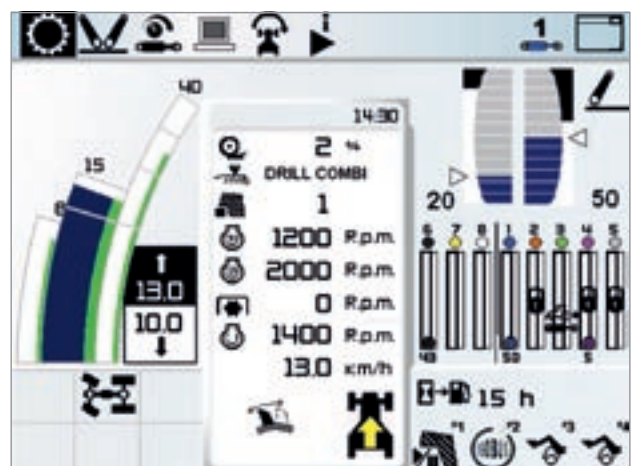

Actuation of the cruise control with the DRIVESTICK.

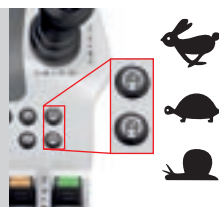

Selection of the three ground speed bands via the multifunction armrest.

CMATIC infinitely variable transmission – adaptable to all working situations.

1. AUTOMOTIVE mode

Auto

- Acceleration with the throttle pedal
- Fully automated engine/transmission management for low fuel consumption
- Pull back DRIVESTICK to use engine braking effect downhill
- The ideal mode for all transport applications

2. DRIVESTICK mode



- Accelerating/decelerating with the DRIVESTICK
- Fully automated engine/transmission management for low fuel consumption
- The right mode when it comes to setting a precise ground speed

3. MANUAL mode



- Engine speed control: foot accelerator or hand throttle
- Transmission ratio: DRIVESTICK
- The driver can shift the gears independently of the engine speed

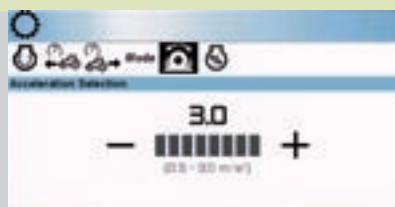

Transmission options

GPS PILOT and CAM PILOT available to increase productivity

CLAAS SEQUENCE MANAGEMENT
Automatic headland control

CEBIS or CIS terminals as intelligent interfaces between driver and AXION

External operation of PTO, linkage and one spool valve on each rear mudguard

Fully integrated front linkage with integrated front PTO shaft, electric and hydraulic couplings

Differential lock and all-wheel management



Intelligent interfaces.



Linkage operation with
traction or wheel slip controls

ISOBUS interface for intelligent
communication with the implements

Up to eight electronic spool valves

PTO shaft management

Numerous equipment options

Rear linkage with over 10 t
maximum lift capacity

The lifting power of a 300-hp tractor.

Broad application range –
AXION and the CLAAS front loader:

- Quick mounting and dismounting without any need for tools
- Simple operation by means of ELECTROPILOT on the armrest
- CLAAS mounting console fully integrated
- Front loader always in view, thanks to the glass roof window
- Stable and efficient combination
- SHOCK ELIMINATOR vibration dampening for exceptional driving comfort
- The large FOPS (Falling Object Protection Structure) transparent sunroof ensures an excellent view of the working area and increased safety when operating



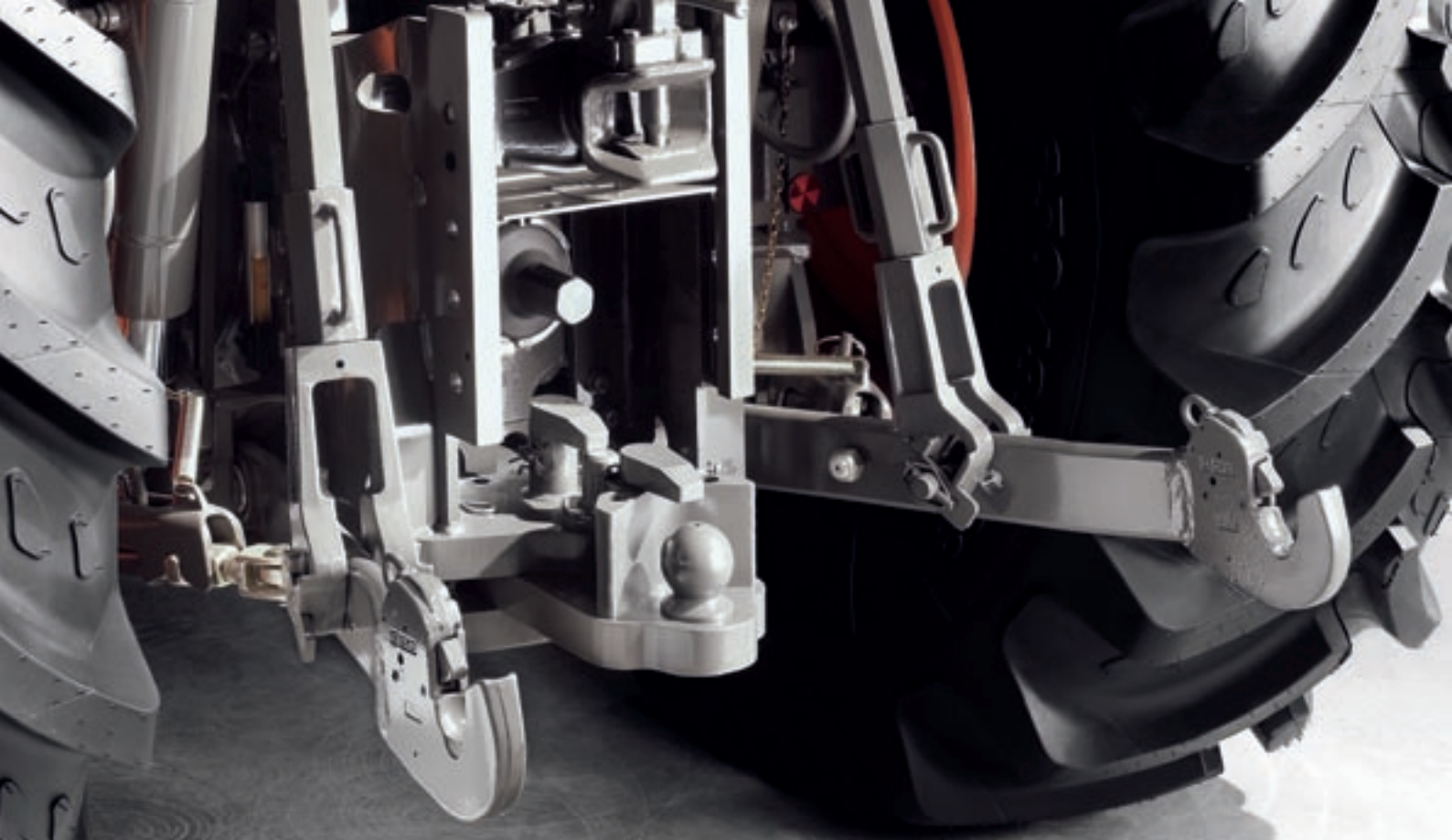

A fully integrated front linkage, ex factory.

When developing the AXION, a fully integrated front linkage with up to 5.4-t lift capacity and a front PTO shaft were envisaged from the outset. Accordingly, this version is available ex factory, and offers many advantages when compared with more conventional retrofitting solutions.

Intelligent linkage.

The operating layout for the rear hydraulics with 10-t maximum lifting capacity was designed specifically for the AXION, and is focused on meeting everyday requirements:

- Draught control
- Load control
- Slip control
- Straightforward operation
- Automatic PTO control

Benefits of the integrated front linkage:

- Perfect transfer of force to the tractor
- High lift capacity
- Integrated front PTO shaft
- Integrated hydraulic and electric connections
- Two lift capacity options (3.3 t and 5.4 t)
- Integrated remote controls
- Load control
- No retrofitting required at the dealer
- Vibration damping

Comfortable operation of the rear linkage.



Front linkage
Rear linkage



The hydraulics of the AXION.

- Load-sensing hydraulics with 110 l/min flow or optional 150 l/min flow for applications with a high oil demand
- Up to four mechanical and two electronic spool valves with CIS equipment
- Up to eight electronic spool valves with CEBIS equipment
- All electronic spool valves with time and volume control via CEBIS
- Remote controls for one electronic spool valve on both rear mudguards
- Power Beyond connections at the rear
- Operation of up to five spool valves via the ELECTROPILOT on the multifunction armrest
- Operation of up to three electronic spool valves via the proportional levers on the multifunction armrest
- CPM provides up to 35 hp boost if hydraulic output falls



Comfortable adjustment of the control device functions with CEBIS.



The matching connection for every implement.

Front and rear PTO shaft.

- 540/1,000 rpm as standard
- 540/540 ECO + 1,000 rpm or 540 ECO, 1,000 + 1,000 rpm ECO optional
- Front PTO shaft (1,000 rpm)
- Remote control switch for front and rear PTO shafts
- Modern PTO shaft management
- Up to 35 hp boost for PTO work with CPM

Numerous implement couplers.

- Drawbar
- Pick-up hitch
- Standard hitch
- Automatic hitch, 38 mm and 32 mm
- CUNA C and CUNA D2/3
- Ball hitch drawbar
- Ball hitch in the slide

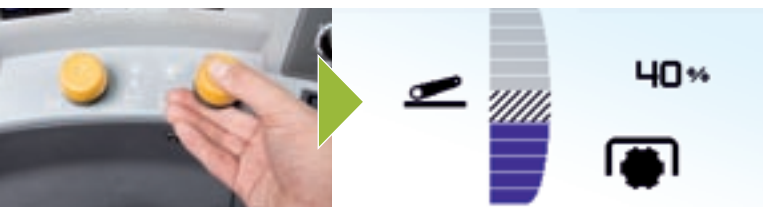
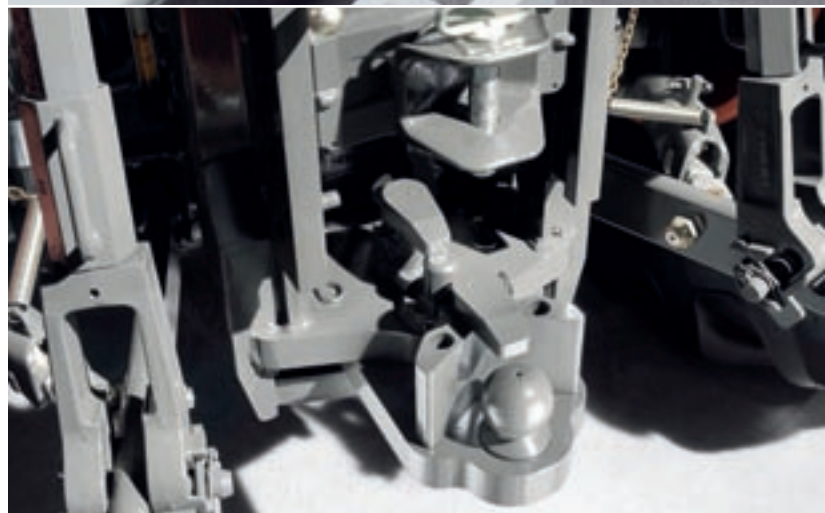

Setting the lift height for automatic PTO engagement with CEBIS.

Hydraulics
Hitching systems
Power take-off

Intelligent tractors can save you a lot of time.

CLAAS SEQUENCE MANAGEMENT.

CSM headland management does the work for you on the headland. Complex operating sequences can be recorded and retrieved at the press of a button.

- Recording of up to four sequences
- Sequences activated by means of buttons on the side and F1/F2 function buttons on the multifunction armrest
- Presentation of the work sequences via CEBIS
- Subsequent changes to CSM processes via the CEBIS terminal

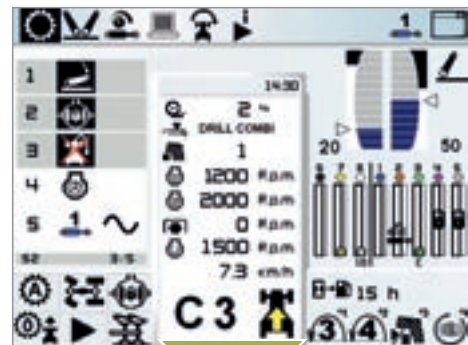

Automatic control of:

- Rear linkage, front linkage
- Up to eight programmable spool valves
- Rear and front PTO shafts
- Transmission gear and engine speed
- Four-wheel drive and differential lock
- Suspended front axle





ISOBUS.

The AXION CEBIS terminal depicts specific tractor functions. To operate ISOBUS-compatible implements together with the AXION, CLAAS offers the COMMUNICATOR. An ISOBUS wiring loom, including a socket on the tractor rear and in the cabin for simple connection of the implement, is available ex factory. Individual implement functions can be operated by means of the COMMUNICATOR or by using the function buttons in the armrest.

Manage implements with CEBIS.

CEBIS makes it possible to store different implements along with their settings and sequences:

- Up to four CSM sequences
- Assignment of function keys on the armrest
- Working width of the implement
- Hectare-count mode (radar speed or wheel speed)
- Criteria for actuation of hectare counter



CSM
ISOBUS

With the GPS PILOT or CAM PILOT, you can save money.



Optimising operating costs.

Research into tillage systems shows that there is often an increase in overlap for greater working widths that do not use a guidance system. That means 7% of diesel fuel, machine costs, fertiliser and pesticide, which could easily be saved with a modern guidance system.

Increase the quality of your work.

CLAAS steering systems take the pressure off the driver. They show in advance which direction to take, or automatically steer the tractor to the best possible track. Mistakes are eliminated, allowing the driver to fully concentrate on keeping the tractor running properly, with clear improvements in the work results.

Correction signal as required.

CLAAS has set up its range of systems in such a way that you can flexibly extend them at any time. This applies just as much to the terminal technology as to using any of today's essential correction signals. All systems can also be retrofitted to the AXION.





GPS PILOT RTK

- Accuracy +/- 2 to 3 cm
- Up to 20 km coverage
- No licence fees
- Maximum steering precision
- Reference signal can be set by the local dealer
- For fleets of machinery or for outsourcing

GPS PILOT RTK NET

- Accuracy +/- 2 to 3 cm
- Charged access to existing RTK networks
- Maximum steering precision
- For machine fleets, with considerable range

GPS PILOT Baseline HD

- Accuracy +/- 4 to 6 cm
- Farm has its own mobile reference station
- Range 3–5 km
- Public reference signal
- Reference station can be used by more than one machine at the same time

Omnistar HP GPS PILOT

- Accuracy +/- 5 to 10 cm
- DGPS dual frequency
- Correction signal received by satellite
- Quarterly or annual licence costs for the reference signal

COPILOT

- Accuracy to within +/- 15–30 cm
- EGNOS satellite signal
- No licence fees
- Manual guidance

CAM PILOT

- 3D camera mounted on the front of the tractor
- Accuracy +/- 5 cm
- Steering hydraulics can be combined with the GPS PILOT
- Tractor follows the rows of plants, tramlines, furrows or swaths

CLAAS steering systems and correction signals are approved and supplied for retrofitting subject to local conditions.

S 3 terminal for controlling the GPS PILOT.



GPS PILOT
CAM PILOT

The AXION opens up new vistas of economic efficiency that will reward you with hard cash.

The engines are designed to be powerful and reliable, while being extremely frugal, and feature a high-precision, high-efficiency transmission. CEBIS takes on the important energy-saving control functions, thus increasing your productivity. Another thing that will surely pay off as well: long maintenance intervals and top CLAAS service.

CEBIS with:

- Implement management
- Fuel consumption indicator
- Work order processing
- Headland management CSM

or CIS with:

- Fuel consumption indicator
- On-board computer

Fuel-saving engine technology

- Variable turbo
- Cooled exhaust gas recirculation
- 4-valve cylinder head
- Common-rail injection system
- Controlled viscous fan
- Electronic injection

Simple maintenance and good access with one-piece bonnet

Electronic powertrain management



With the AXION, every minute of operation pays off.

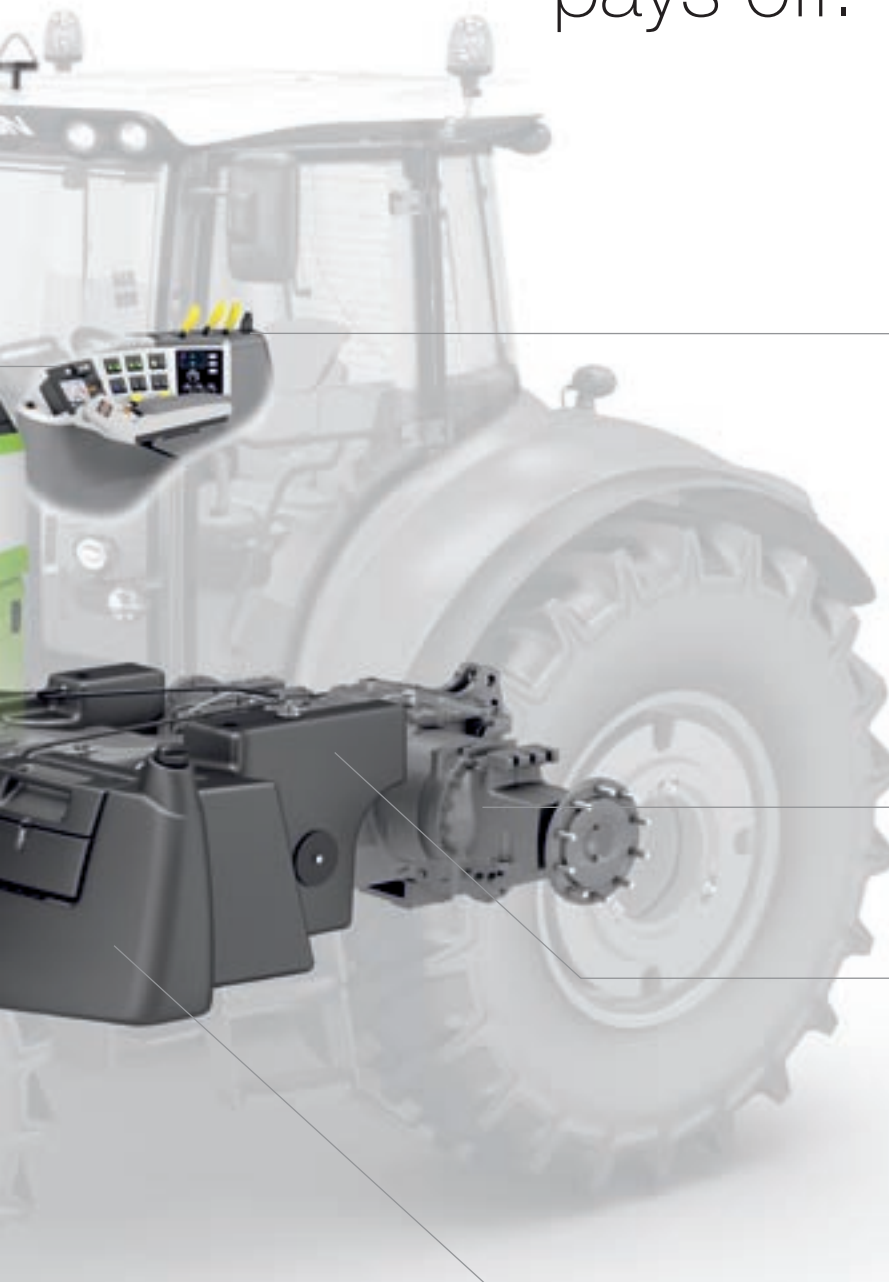

ECO PTO drive

Drive line designed for high mechanical efficiency

Split-power CMATIC transmission with low hydraulic element and high mechanical transfer level for top efficiency

Large fuel tank with capacity up to 503 l (HEXASHIFT 840 and 850)

+ FIRST CLAAS SERVICE® around the clock

Economic efficiency

We can't lower the price of diesel, but we can lower the consumption.

A constant power range of 600 rpm and a torque increase of 43% are the impressive performance statistics presented by the AXION. But higher output doesn't necessarily imply higher consumption. On the contrary – thanks to the engine technology used here, as well as the CPM, not a single litre of valuable diesel is wasted. Additional output is mobilised only if required.

The automatic HEXASHIFT transmission makes another valuable contribution, allowing you to work efficiently and economically. Its outstanding efficiency puts it in a class of its own and guarantees just the right engine and working speed in any application. Regardless of the speed you work at, low operating costs are our first priority. With the infinitely variable CMATIC transmission, a large portion of the power is transmitted mechanically. This keeps the mechanical efficiency high and fuel consumption low in all conditions, in conjunction with the sophisticated powertrain management system on board.





Profi Test (4/08) evaluation:

The AXION 850 was tested by the independent testing agency of the German Agricultural Society (DLG). The tests measured the tractor's engine and tractive power.

The Profi editors wrote:

"The result of the Powermix measurements is what impressed us most during testing: our test candidate consumed a good 7% less diesel fuel on average across every working operation. In difficult operating conditions, this means a saving of 2.5 litres per hour."

Low consumption, thanks to AXION technology.

- Perfectly matched transmission and rear axle for a high degree of efficiency
- Engines with
 - Variable turbo
 - Exhaust gas recirculation
 - 4-valve cylinder head
 - Common-rail injection system
 - Viscous fan
 - Electronic injection
- Low power-to-weight ratio from 33 kg/hp (45 kg/kW)
- Rear tyres up to 2.05 m in diameter for good tractive force transmission
- Electronic powertrain management
- CLAAS POWER MANAGEMENT (CPM) with step-by-step release of additional engine output
- 40 km/h or 50 km/h at reduced speeds

Saving fuel



Quick maintenance, thanks to easy accessibility.

The AXION clearly comes up trumps in terms of maintenance. The one-piece bonnet allows you easy access to all the important service and maintenance points, and easy exchange of parts. This means that all maintenance operations can be conducted with just a few simple steps.

- Simple oil check
- Easy to top up
- Quick cleaning or replacement of the air filter
- Straightforward cleaning of the cab air filter
- Each radiator is easily accessible

Lower costs, thanks to long maintenance intervals.

The AXION boasts particularly long service intervals. This means that you can get loads of jobs under your belt before having to think about maintenance – and you don't need to tie a knot to remember when the next service is due. CEBIS or CIS look after your schedule and notify you in good time.

The benefits for you:

- You have access to the most important maintenance points
- CEBIS or CIS keeps you up to date with regard to the maintenance status
- You can carry out simple maintenance operations yourself
- Long maintenance intervals allow you greater flexibility of operation
- Long-term maintenance also means lower costs

Service Item	Hours
Next service 10 hours	10 h
Next service 50 hours	50 h
Next service 100 hours	100 h
Next service 200 hours	200 h
Next service 1000 hours	1000 h

CEBIS or CIS always keeps you informed about the service status on your AXION.

Shorter maintenance times.
Longer service intervals.



Lowering maintenance costs

CEBIS manages everything that might affect your concentration.



Excellent task management.

One name says it all: CLAAS CEBIS. It provides a good overview and facilitates comprehensive, perfect task management. You can determine and change the settings, program processes and have the task status displayed. Of course, all kinds of implement settings and headland frequencies can also be saved. All this speeds up work order processing enormously, with a positive impact on profitable work patterns.



Efficient display.

The high-contrast display is large and straightforward, with quick access to the menus. Nothing will distract or irritate you, as you'll see only the information required at that particular moment. A smooth-running selector facilitates precise and intuitive operation.

An overview of all need-to-know information with CIS:

- Fuel consumption
- Finished surface area
- Area output
- Remaining working hours

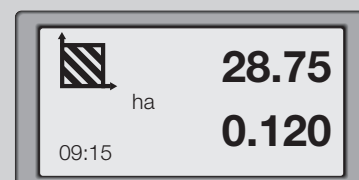
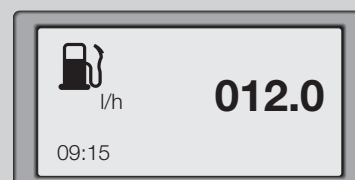



0.045
 ha/h
0.043
 09:15

008.3
 h
 09:15

Increasing productivity



FIRST CLAAS SERVICE® around the clock.

Our years of experience and enormous knowledge base have familiarised us like no one else with the working methods and individual requirements of every farming business. So we know exactly what it all comes down to, including the service aspects. Our FIRST CLAAS SERVICE® package is therefore synonymous with absolute reliability and professionalism.

We are there for you when you need us.

We provide your farm with the required ORIGINAL CLAAS spare parts any time – reliably and, most importantly, fast, keeping potential downtime as short as possible. You know as well as we do – time is money.

CAN BUS technology in the AXION.

The AXION communicates via four CAN BUS systems which replace the old-fashioned wiring to all the user functions. Up to 15 controllers are connected via the CAN data bus, a joint communication circuit. This saves up to 1.5 km of cable, facilitates innovative solutions such as the CSM headland management, and significantly eases service and diagnosis.

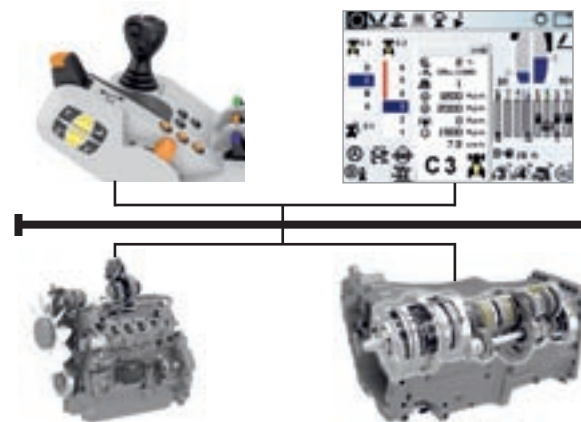

Good partners never leave you in the lurch – no matter what time of day it is.

Dedicated teams.

Our service teams enjoy their work and know exactly what they're talking about, because expert knowledge and commitment are the perfect basis for successful teamwork. That means you'll always be the kind of customer we're happy to have – entirely satisfied.



ISOBUS



CAN BUS



Ensuring reliability in the field

Features to win you over:

Comfort.

- 4-point suspended cab
- CEBIS terminal for monitoring and adjusting machine setting
- Suspended front axle
- Multifunction armrest
- DRIVESTICK for operating the transmission
- Long wheelbase with shorter overall length
- Air-suspended low-frequency seat
- Vibration absorption of front and rear linkages
- Automatic climate control
- MP3 radio with Bluetooth function

Versatility.

- AXION 810 to 850 with rated output from 163 to 225 hp to ECE R 24 standard
- The AXION 850 offers maximum power output of 260 hp with CLAAS POWER MANAGEMENT
- High power-to-weight ratio
- Rear tyre diameters up to 2.05 m
- Up to 700 kg weight per rear wheel
- HEXASHIFT transmission or CMATIC infinitely variable transmission
- Fully integrated front linkage
- Four PTO speeds available

Intelligence.

- Headland management CSM
- Up to eight electronic spool valves
- External operation of front linkage, rear linkage, PTO shaft and an electronic spool valve
- GPS guidance and optical steering
- Fully integrated front linkage and front PTO shaft
- Numerous equipment options
- ISOBUS-ready
- Automatic engagement/disengagement of four-wheel drive, differential and PTO

Economic efficiency.

- Top engine technology for low fuel consumption
- 40 km/h or 50 km/h at reduced speeds
- Matched transmission and rear axle for high efficiency
- Extended maintenance intervals
- Good accessibility
- Job processing and performance monitor
- CAN BUS technology
- FIRST CLAAS SERVICE®

AXION

		850	840	820	810
Hydraulics					
Load-sensing circuit		●	●	●	●
Output at rated speed standard (option)	l/min	110 (150)	110 (150)	110 (150)	110 (150)
Max. operating pressure	bar	200	200	200	200
Number of auxiliary spool valves (min.–max.)		3–8	3–8	3–8	3–8
Number of mechanical spool valves (min.–max.)		3–4	3–4	3–4	3–4
Quantity control		●	●	●	●
ELECTROPILOT 4-way control		○	○	○	○
Rear linkage					
Max. lifting power at ball ends	kg	10229	9676	9460	9460
Continuous lifting power at 610 mm	kg	6,251	6,251	6,251	6,251
Lifting range	mm	850	850	850	850
Vibration damping		●	●	●	●
Active slip control		○	○	○	○
25-ampere socket		●	●	●	●
Front linkage					
Lift capacity	t	3.3/5.4	3.3/5.4	3.3/5.4	3.3/5.4
Front PTO rpm		○	○	○	○
External operation		○	○	○	○
Hydraulic connections		max. 5	max. 5	max. 5	max. 5
Trailer plug		●	●	●	●
Cab					
CEBIS with electronic spool valves		●	●	●	●
CIS with mechanical spool valves		●	●	●	●
4-point suspension		●	●	●	●
Multifunction armrest		●	●	●	●
Air conditioning		●	●	●	●
Automatic climate control		○	○	○	○
Passenger seat		●	●	●	●
Cooler compartment		●	●	●	●
Dimensions					
Rear wheels		620/70 R 42	620/70 R 42	20.8 R 38	20.8 R 38
Front wheels		480/70 R 30	480/70 R 30	16.9 R 28	16.9 R 28
Length with front ballast and trailer hitch (e)	mm	5721	5721	5721	5721
Centre rear axle – cab upper edge (a)	mm	2,278	2,278	2,278	2,278
Overall height (b)	mm	3203	3203	3153	3153
Wheelbase (c)	mm	2985	2985	2985	2985
Clearance, rear axle – lower link (d)	mm	1,353	1,353	1,353	1,353
Weight					
(standard tyres, with oil and fuel, without driver)					
Rear wheels		580/70 R 42	20.8 R 42	20.8 R 38	20.8 R 38
Front wheels		480/70 R 30	16.9 R 30	16.9 R 28	16.9 R 28
Weight without ballast	kg	8098	7416	7238	7148
Max. front ballast without front lift linkage	kg	1,454	1,454	1,454	1,454
Weight distribution with ballast (rear/front)	%	50/50	49/51	49/51	48/52
Max. permissible gross weight (40-km/h version)	kg	14,000	12,000	12,000	12,000
Max. permissible gross weight (50-km/h version)	kg	12,000	12,000	12,000	12,000
Ground clearance					
Front axle (f)	mm	587	587	568	568
Rear axle (g) (without drawbar)	mm	564	564	515	515

● Standard ○ Optional – Not available

AXION

		850	840	820	810
Tyres (standard axle or sprung front axle)					
Rear tyres	Front tyres				
20.8 R 38 (520/85 R 38)	16.9 R 28 (420/85 R 28)	–	–	◻	◻
	480/70 R 28	–	–	◻	◻
20.8 R 42 (520/85 R 42)	16.9 R 30 (420/85 R 30)	–	◻	◻	◻
	480/70 R 30	–	◻	◻	◻
580/70 R 38	16.9 R 28 (420/85 R 28)	–	–	◻	◻
	480/70 R 28	–	–	◻	◻
	540/65 R 28	–	–	◻	◻
580/70 R 42	16.9 R 30	–	◻	◻	◻
	480/70 R 30	◻	◻	◻	◻
	540/65 R 30	–	◻	◻	◻
620/70 R 42	16.9 R 30 (420/85 R 30)	–	◻	◻	◻
	480/70 R 30	◻	◻	◻	◻
	540/65 R 30	◻	◻	◻	◻
	600/65 R 28	◻	◻	◻	◻
650/65 R 38	480/70 R 28	–	–	◻	◻
	540/65 R 28	–	–	◻	◻
650/65 R 42	480/70 R 30	◻	◻	◻	◻
	540/65 R 30	◻	◻	◻	◻
	600/65 R 28	◻	◻	◻	◻
650/75 R 38	480/70 R 30	◻	◻	◻	◻
	540/65 R 30	–	◻	◻	◻
	600/65 R 28	◻	◻	◻	◻
710/70 R 38	480/70 R 30	◻	◻	◻	◻
	600/65 R 28	◻	◻	◻	◻
710/60 R 38	600/60 R 28	–	–	–	◻
710/60 R 42	600/60 R 30	–	–	◻	◻
650/85 R 38	480/70 R 34	◻	◻	–	–
	540/65 R 34	◻	◻	–	–
	600/70 R 28	◻	◻	–	–
	600/70 R 30	◻	◻	–	–
	620/70 R 28	◻	◻	–	–
710/70 R 42	480/70 R 34	◻	◻	–	–
	540/65 R 34	◻	◻	–	–
	600/70 R 28	◻	◻	–	–
	600/70 R 30	◻	◻	–	–

● Standard ○ Optional ◻ Available – Not available

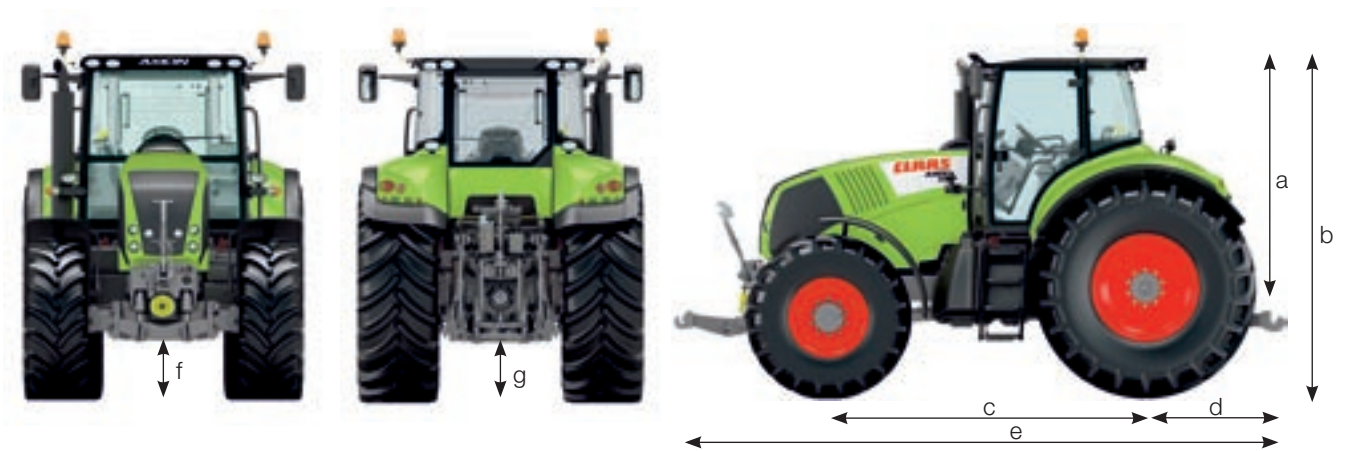

CLAAS continually develops its products to meet customer requirements. This means that all products are subject to change without notice. All descriptions and specifications in this brochure should be considered approximate and may include optional equipment that is not part of the standard specifications. This brochure is designed for worldwide use. Please refer to your nearest CLAAS dealer and their price list for local specification details. Some protective panels may have been removed for photographic purposes in order to present the function clearly. To avoid any risk of danger, never remove these protective panels yourself. In this respect, please refer to the relevant instructions in the operator's manual.

Specifications

AXION

		850	840	820	810
Engine					
Manufacturer		DPS	DPS	DPS	DPS
Number of cylinders / intake		6/TI	6/TI	6/TI	6/TI
Cubic capacity	cm ³	6788	6788	6788	6788
Nominal engine speed	rpm	2200	2200	2200	2200
Output at nominal engine speed (ISO TR 14396 ¹)	kW/hp	171/233	156/212	139/189	125/170
Max. output (ISO TR 14396 ¹)	kW/hp	175/238	157/213	145/197	132/180
Max. output with CPM (ISO TR 14396 ¹)	kW/hp	197/268	181/246	170/232	157/214
Output at nominal engine speed (ECE R 24)	kW/hp	165/225	151/205	135/183	120/164
Max. output (ECE R 24)	kW/hp	169/230	154/210	142/193	129/176
Max. output with CPM (ECE R 24)	kW/hp	193/260	177/240	166/227	153/209
Output at nominal engine speed : (97/68 EC2)	kW	187	180 ³	165	150
Max. output at engine speed	rpm	2000	2000	2000	2000
Constant output	rpm	600	600	600	600
Engine speed at max. torque	rpm	1500	1500	1500	1500
Max. torque	Nm	1,020	950	895	792
Electronically controlled injection pump		●	●	●	●
Air filter dust aspiration		●	●	●	●
Fuel tank capacity (HEXASHIFT/CMATIC)	l	503	503/377	407/377	407/377
Oil-change interval	h	500	500	500	500
HEXASHIFT transmission					
Ratios F/R		24/24	24/24	24/24	24/24
Ground speed (min./max.) 40-km/h version	km/h	1.58/40	1.69/40	1.72/40	1.72/40
Ground speed (min./max.) 50-km/h version	km/h	1.58/50	1.69/50	1.72/50	1.72/50
REVERSHIFT clutchless reverser		●	●	●	●
Number of powershift steps		6	6	6	6
Electrically controlled ranges		4	4	4	4
HEXACTIV		●	●	●	●
Creep range	km/h	0.39	0.42	0.43	0.43
CMATIC transmission					
CMATIC infinitely variable transmission		–	○	○	○
Ground speed (min./max.) 40-km/h version	km/h	–	0.05/40	0.05/40	0.05/40
Ground speed (min./max.) 50-km/h version	km/h	–	0.05/50	0.05/50	0.05/50
REVERSHIFT clutchless reverser		–	●	●	●
Rear axle					
Electrohydraulically connected differential locks		●	●	●	●
Automatic differential locks		●	●	●	●
Max. rear tyres		710/70 R 42	710/70 R 42	710/70 R 38	710/70 R 38
Power take-off					
Wet multidisc clutch		●	●	●	●
Remote control engagement and emergency stop		●	●	●	●
540/1000		●	●	●	●
540/540E/1000 or 540E/1000/1000E		○	○	○	○
Changeable PTO shaft stub		●	●	●	●
Number of splines		6/21	6/21	6/21	6/21
4-wheel drive front axle					
Electrohydraulic operation		●	●	●	●
Automatic 4-wheel drive		●	●	●	●
Max. steering angle	Degrees	55	55	55	55
Castor angle	Degrees	5	5	5	5
Angle of oscillation	Degrees	10	10	10	10
Turning radius	m	5.19	5.19	5.15	5.15
Track	mm	1,996	1,996	1,968	1,668
with tyres		480/70 R 30	480/70 R 30	16.9 R 28	16.9 R 28
Wet multidisc clutch		●	●	●	●
PROACTIV suspended front axle		○	○	○	○
Pivoting mudguards		●	●	●	●

● Standard ○ Optional – Not available

¹ Compliant with ECE R 120 (approx.) ² Performance data fit criteria for admissibility. Performance as per 97/68/EC is identical to 2000/25/EC.

³ 175 kW with HEXASHIFT transmission



CLAAS UK
Saxham
Bury St. Edmunds
Suffolk
IP28 6QZ
Tel 01284 763100
claas.co.uk
info-uk@claas.com
321012130511 CR Be 0911