

ARION  
430 420 410

**CLAAS**

One for all.



Good genes.



# ARION

	430 CIS	430	420 CIS	420	410 CIS	410
<b>Engine</b>						
Manufacturer	DPS	DPS	DPS	DPS	DPS	DPS
Number of cylinders/intake	4/TI	4/TI	4/TI	4/TI	4/TI	4/TI
Common rail injection	●	●	●	●	●	●
Cubic capacity	cm <sup>3</sup>	4525	4525	4525	4525	4525
Nominal engine speed	rpm	2200	2200	2200	2200	2200
Engine speed at maximum output	rpm	2100	2000	2000	2000	1900
Output at nominal engine speed (97/68/EC <sup>1</sup> )	kW/hp	98/133	89/121	90/122	81/110	83/113
Output at nominal engine speed (ECE R 120 <sup>2</sup> )	kW/hp	85/115	85/115	77/105	77/105	70/95
Max. output (ECE R 120 <sup>2</sup> )	kW/hp	88/120	88/120	81/110	81/110	75/100
Max. output with CPM (ECE R 120 <sup>2</sup> )	kW/hp	95/130	–	88/120	–	81/110
Output at nominal engine speed (ECE R 24)	kW/hp	81/110	81/110	75/100	75/100	66/90
Max. output (ECE R 24)	kW/hp	85/115	85/115	77/105	77/105	70/95
Max. output with CPM (ECE R 24)	kW/hp	92/125	–	85/115	–	77/105
Constant output	rpm	400	400	400	550	300
Max. torque (ECE R 120 <sup>2</sup> )	Nm	495	495	465	465	420
Max. torque with CPM (ECE R 120 <sup>2</sup> )	Nm	510	–	500	–	460
Engine speed at max. torque	rpm	1200–1650	900–1650	1300–1650	900–1650	1000–1650
Torque increase	%	31	39	39	43	45
Max. fuel capacity	l	175	175	175	175	175
Oil change interval	h	500	500	500	500	500
<b>Transmission</b>						
Ratios F / R		16/16	16/16	16/16	16/16	16/16
Max. speed at 2200 rpm	km/h	1.97	1.97	1.97	1.97	1.97
Max. speed	km/h	40	40	40	40	40
REVERSHIFT clutchless reverser		●	●	●	●	●
Number of powershift steps		4	4	4	4	4
Electronically controlled groups		4	4	4	4	4
QUADRACTIV		○	–	○	–	○
Joystick for gear changing		○	–	○	–	○
Min speed with creep gear	km/h	0.14	0.14	0.14	0.14	0.14
<b>Rear axle</b>						
Electrohydraulically connected differential locks		●	●	●	●	●
Automatic differential locks		●	●	●	●	●
Max. rear tyres		600/65 R 38	600/65 R 38	600/65 R 38	600/65 R 38	600/65 R 38
<b>PTO</b>						
Wet multi-disc clutch		●	●	●	●	●
Remote control emergency stop		●	●	●	●	●
Remote control actuation		●	○	●	○	○
540/1000		●	●	●	●	●
540/540E/1000/1000E		○	○	○	○	○
PTO shaft management		●	–	●	–	–
Changeable PTO shaft stub		●	●	●	●	●
Number of splines		6/21	6/21	6/21	6/21	6/21

● Standard ○ Optional – Not available

<sup>1</sup> Performance data fit criteria for admissibility. Performance as per 97/68/EC is identical to 2000/25/EC.

<sup>2</sup> Complies with ISO TR 14396

# ARION

	430 CIS	430	420 CIS	420	410 CIS	410
<b>4-wheel drive front axle</b>						
Electrohydraulic operation		●	●	●	●	●
Automatic 4-wheel drive		●	●	●	●	●
Max. steering angle	Degrees	55	55	55	55	55
Castor angle	Degrees	6	6	6	6	6
Angle of oscillation	Degrees	10	10	10	10	10
Turning radius	m	4.4	4.4	4.4	4.4	4.4
Track	mm	1950	1950	1950	1950	1950
with tyres		13.6 R 28	13.6 R 28	13.6 R 28	13.6 R 28	13.6 R 28
Rigid or swivelling mudguards		○	○	○	○	○
<b>Hydraulics</b>						
Max. operating pressure	bar	195	195	195	195	195
Open hydraulic circuit I		○	●	○	●	○
Flow at rated speed	l/min	60	60	60	60	60
Open hydraulic circuit II		●	○	●	○	○
Flow at rated speed	l/min	98	98	98	98	98
Quantity control		●	●	●	●	●
2 electronic spool valves with joystick operation		○	–	○	–	○
Number of control valves (min.–max.)	min/max	2/4	2/4	2/4	2/4	2/4
<b>Rear linkage</b>						
Max. lifting power at ball ends	kg	6500	6500	6500	6500	6500
Continuous lifting power at 610 mm	kg	4100	4100	4100	4100	4100
Vibration damping		●	●	●	●	●
External operation for rear linkage		●	●	●	●	●
Trailer hydraulic brake		○	○	○	○	○
Air brake system		○	○	○	○	○
<b>Cab</b>						
Air conditioning		○	○	○	○	○
CIS (CLAAS INFORMATION SYSTEM)		●	–	●	–	–
Cooler compartment		○	○	○	○	○
Passenger seat		●	●	●	●	●
MP3 Bluetooth Radio		○	○	○	○	○
Air-suspended low-frequency seat		○	–	○	–	○
Noise level	db(A)	72	72	72	72	72

● Standard ○ Optional – Not available

CLAAS is continually developing its products to meet customer requirements. Hence all products are subject to change without notice. All descriptions and specifications provided in this brochure are to be considered approximate and may include optional extras outside the standard specifications. This brochure is designed for worldwide use. For local specification details please refer to your nearest CLAAS dealer and corresponding price list. The photos may in some cases show protective panels that have been removed. This was only done for the purpose of presenting certain functions more clearly and, to avoid any endangerment, must never be removed by unauthorised persons. In this respect, please refer to the relevant instructions in the operator's manual.



For CLAAS, consistently meeting the requirements of day-to-day practice is crucial in developing its new machines. The ARION series, too, has been developed on this basis. With their superb driving and operating comfort, flexibility, economic running and reliable engineering, the ARION 500 and 600 have become firmly established on the market.

In developing the ARION 400, CLAAS has met the challenge of adapting the technology of the top performance classes to meet the requirements of farmers looking for a smaller package: proven technology in a compact, modern design in conjunction with premium-range comfort and ergonomics.

A long wheelbase, optimal weight distribution and perfect coordination of the engine and transmission are just some of the benefits of the CLAAS Tractor Concept that give CLAAS its crucial edge over the competition.





## Contents

<b>Good genes.</b>	<b>2</b>
4-cylinder tractors from CLAAS	6
Range of applications	8
Forage harvesting, tillage	10
Transport, front loader	12
Maintenance and yard work	14
<b>More power to the wheels.</b>	<b>16</b>
Drive	8
Engine	20
Transmission	22
Architecture	24
Hydraulics and PTO	26
Front loader	28
<b>More productivity at the wheel.</b>	<b>30</b>
Ergonomics	32
Cab	34
Maintenance	36
<b>A smarter system.</b>	<b>38</b>
CLAAS INFORMATION SYSTEM	40
QUADRACTIV	42
Automatic functions	44
Joystick	46
Guidance systems	48
FIRST CLAAS SERVICE®, MAXI CARE®	50
Specifications	54



## A powerful trio.

In the 100 hp class, CLAAS is represented by three 4-cylinder model series, covering a power range from 74 to 155 hp. The ARION 400 combines many excellent characteristics from different performance classes, and offers everything that you require from a compact tractor.

You benefit from excellent manoeuvrability and a low overall height, as with the AXOS 300, but you also have features available such as a hydraulic flow of up to 98 l/min with comfortable, cross-command joystick operation and an integrated, automatic transmission shifting function. In addition, you also have engine performance similar to that of an ARION 500, but combined into a smaller-dimensioned package (2.74 metres minimum overall height and 4.44 metres overall length). All these features make the ARION 400 the perfect all-rounder for every farm.

## ARION 540 530 520 510

- DPS 4-cylinder engines
- common rail injection system
- VGT turbocharger and external exhaust gas recirculation
- Max. output 112–135 hp to ECE R 24 standard
- 20 hp boost output in the ARION 540 (max. output 155 hp)
- HEXASHIFT transmission with HEXACTIV automatic shifting
- 4-point cab suspension
- Multifunction armrest
- CEBIS terminal, optional with up to six electronic spool valves
- Optional PROACTIV suspended front axle
- Optional load-sensing hydraulics with a flow of 110 l/min
- Choice of CIS or CEBIS equipment



## ARION 430 420 410

- DPS 4-cylinder engines
- common rail injection system
- Turbocharger and internal exhaust gas recirculation
- Max. output 95–115 hp to ECE R 24 standard plus additional 10 hp boost output in the CIS version
- QUADRISHIFT powershift transmission with QUADRACTIV automatic shifting
- Up to four spool valves (two mechanical and two electronic via joystick)
- Maximum hydraulic flow 98 l/min

## AXOS 340 330 320 310

- Perkins 4-cylinder engines
- Mechanical injection
- Turbocharger and internal exhaust gas recirculation
- Output at nominal engine speed 74–100 hp (ECE R 24)
- Synchronised reverser or REVERSHIFT clutchless reverser with TWINSHIFT powershift
- Up to four mechanical spool valves
- Maximum hydraulic flow 60 l/min

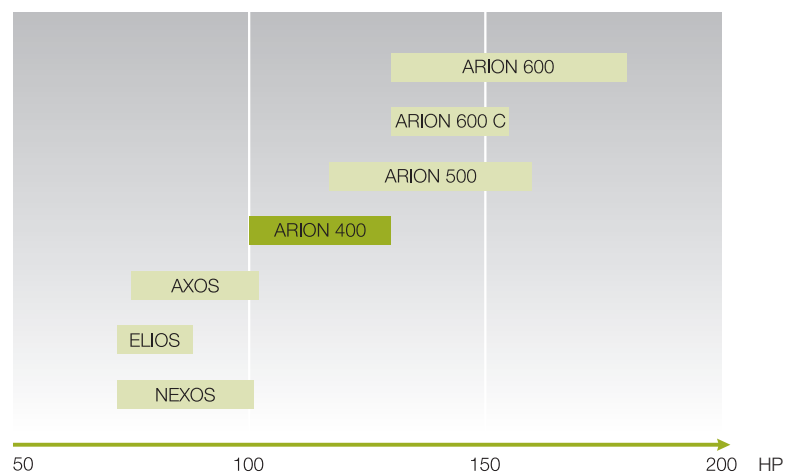







## For any job – for any driver.

The technology of the premium class, implemented and adapted to meet the requirements of the mid-range customer – the impressive features of the AXION, ARION 600 and ARION 500 model ranges can now be found on the ARION 400 as well.

Maximum output from 90 hp, designed and built for everyday use. The ARION 400 offers a wide range of applications in a compact format – for mowing, baling, ploughing, spraying, and in front-loader or transport work.

Whatever your application, the ARION 400 can be recommended for every task and every driver. Its all-round, simple operation makes it easy for any driver to master the day's challenges without the need for lengthy prior instruction.





## Green harvest.

With PTO shaft speeds of 540/1000 or 540/1000/540 ECO/1000 ECO rpm, you can easily master arduous jobs or save fuel in light work.

- 10 hp boost available from transmission range C upwards, for PTO work, for hydraulic power, and to compensate when the viscous fan is actuated
- Fully integrated front linkage with 2.8 t lifting capacity
- High manoeuvrability, thanks to minimal overhangs
- Optimal control of front-mounted equipment with coupling points close to the front axle
- Perfect handling, thanks to the electrohydraulic joystick for operating:
  - the front hydraulic system, rear spools, and the transmission
  - the front loader, the transmission, and the 3rd and 4th function

## Tillage.

The extended wheelbase and optimal weight distribution of the ARION 400 ensure the highest degree of tractive power and stability in the field.

- Up to 6.5 t max. lift capacity in the CIS version
- 10 hp boost available from transmission range C upwards, for PTO work, for hydraulic power, and to compensate when the viscous fan is actuated
- Automatic PTO engagement/disengagement
- QUADRISHIFT powershift transmission with QUADRACTIV automatic shifting
- Two electronic spool valves with time and flow control, ideal for tracking indicator and for use with reversible plough



## Transport.

The QUADRISHIFT transmission available with QUADRACTIV powershift unit guarantees a simple and relaxed driving experience on the road, with no gear-shifting.

- Up to 500 Nm torque, thanks to the 4.5-litre DPS turbocharged engine
- 10 hp boost from range C on the CIS variant
- Pneumatically suspended or low-frequency seat
- Long wheelbase for good road handling





## Front loader.

Order your CLAAS front loader direct ex factory. The frame and all hydraulic and mechanical connections are perfectly integrated into the tractor.

- No impairment of accessibility or ground clearance
- Excellent operational safety and pushing force, thanks to the long wheelbase and corresponding weight distribution
- Safe operation, thanks to unrestricted view from cab with FOPS (Falling Object Protection Structure) transparent sunroof
- REVERSHIFT for fast and comfortable direction changes
- Rotary dash control to adjust the response characteristics (in the CIS variant)
- Unique joystick: electrohydraulic cross command for operating the front loader and the transmission (shifting up/down), or alternatively operation with FLEXIPILOT (low-pressure hydraulic operation)
- Hydraulic flow of up to 98 l/min available for improved cycle times





### Top work.

Thanks to the high lift capacity and extended wheelbase, even heavy attachments can be used with no problems.

- Economical operation, thanks to ECO PTO
- Manoeuvrable in any situation, thanks to the small turning radius (4.40 m) achieved by a steering angle of 55 degrees
- Automated CAM PILOT steering system to facilitate manoeuvring in row crops, furrows and along tramlines
- High payload possible through permissible overall weight of 8.8 t

### Yard work.

Thanks to its compact dimensions, the ARION 400 impresses with its high degree of manoeuvrability, even with front linkage.

- Overall height 2.74 m (tyres 16.9 R 34)
- Comfortable operation when using the front loader
- Problem-free manoeuvring in tight spaces or in farm buildings, thanks to the electrohydraulic joystick for front-loader and transmission operation







**CPS** | CLAAS  
POWER  
SYSTEMS

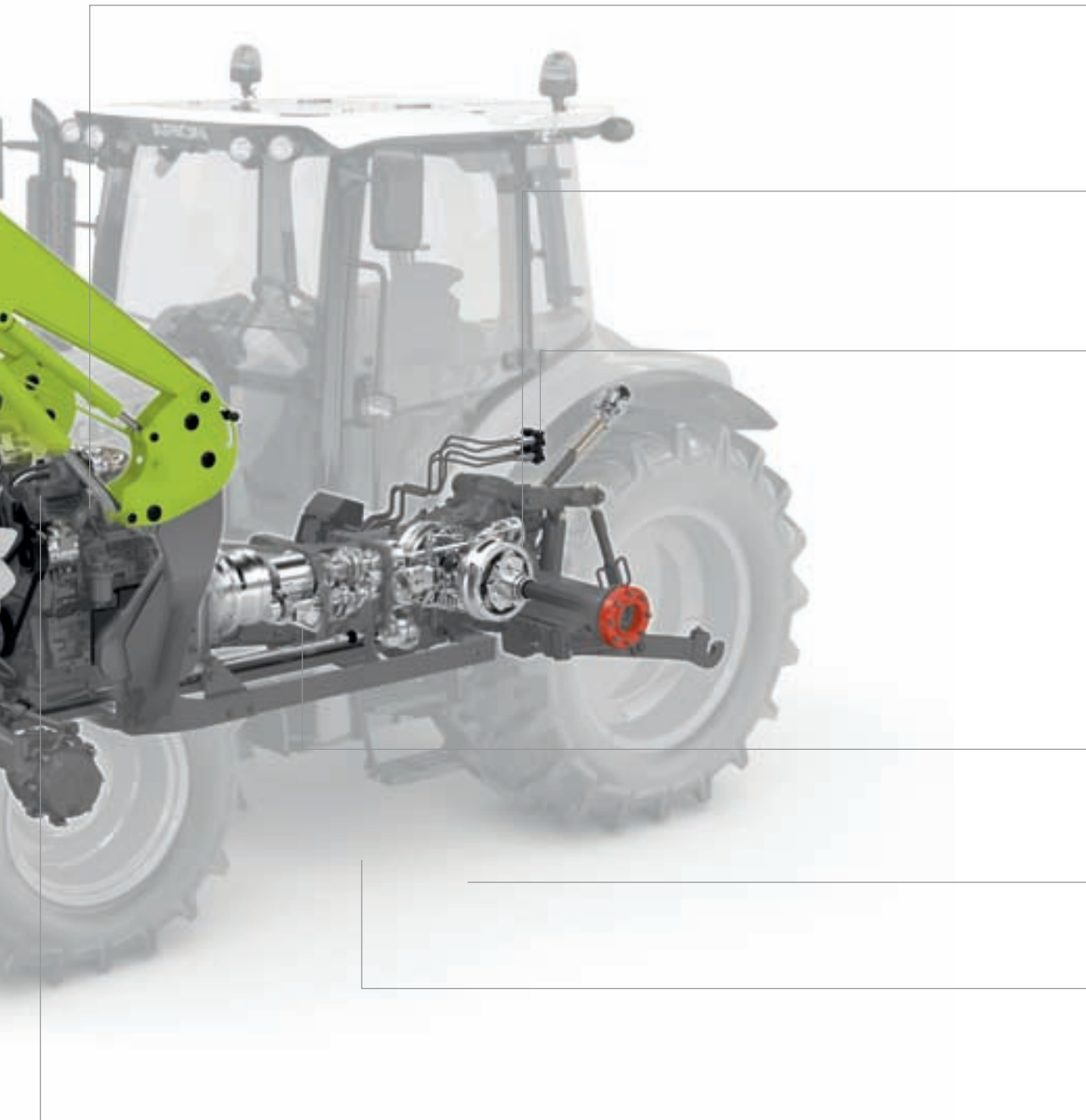



### Optimal drive for best results.

At CLAAS, machine development means an ongoing effort to achieve even greater efficiency and reliability as well as optimal profitability in the field. The CLAAS ARION 400 is no exception; the entire drive train is of the utmost importance and encompasses much more than just a powerful engine.

In CLAAS POWER SYSTEMS (CPS), we have brought together top-quality components to create a drive system that is in a class of its own – one that always delivers the most efficient power when needed. CPS is ideally matched to the working system, featuring fuel-saving technology that quickly pays for itself. Power equals efficiency.

## Power and intelligence in one.

The ARION 400 has been developed on the following principle: performance losses in the drives are minimised in order to channel as much power as possible to where it belongs – the wheels, PTO shaft and vehicle hydraulics – and at an extremely efficient rate of fuel consumption.

In order to further increase the mechanical efficiency of the ARION 400, CLAAS engineers have developed an electronic control system to get the best out of all the components. For example, the transmission control is adapted to the current engine output, in order to make gear shifting even smoother and more precise.

Systems such as CLAAS POWER MANAGEMENT, QUADRISHIFT and QUADRACTIV ensure greater efficiency and intelligent performance, enabling the ARION to tap its full potential in your day-to-day work in the field.



## Perfect engine matching.

As with existing drive lines on the proven ARION model series, the engine of the ARION 400 is distinguished by its delivery of power and reliability. The performance curve of the common rail engine has been specially matched to the ARION 400 in order to achieve a more constant output with an excellent ability to "hang on".

The engine is very responsive in every speed range, and always reacts quickly to changes in load – as is especially evident in front-loader work and transport.

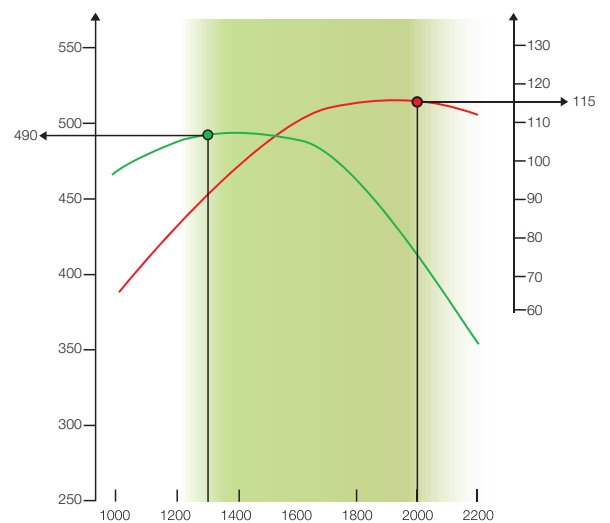



### Plenty in reserve.

With CLAAS POWER MANAGEMENT (CPM), the ARION 400 CIS provides up to 10 hp additional output. The additional output is released in four steps, depending on the requirement for tractive power, PTO output or hydraulic power consumption. Only the exact amount of fuel required is injected.

Up to 10 hp additional output is developed under the following conditions:

- Transmission in range C or D (C1 = 6 km/h at 1400 rpm)
- reduction in hydraulic power
- reduction in PTO shaft output
- Actuation of the viscous fan

### Full power.

Sophisticated engine technology ensures top performance in the ARION 400. Especially in difficult conditions, the engine will develop its full potential and won't let you down.

- Output from 90–125 hp to ECE R 24 standard
- Complies with emission standard Stage IIIa (Tier 3)
- Common rail technology
- Internal exhaust gas recirculation
- Turbocharger with intercooler
- CPM CLAAS POWER MANAGEMENT





## The QUADRISHIFT transmission from CLAAS.

With four powershift ranges and four powershift splits, you can optimally match the speed of the ARION 400 to the conditions on the ground. On the road or around the farm, you can comfortably select any one of four hydraulically selected ranges without having to use the foot clutch. The perfect combination of operation, high efficiency and versatility in this performance class: the ARION 400.

16 gears at the push of a button.

- No more range shifting with the clutch and gear lever
- REVERSHIFT for comfortable shuttling
- Nine gears in the main working range
- Easy and comfortable operation with the shift lever or cross-command joystick
- Good efficiency in the field and on the road for low fuel consumption
- CLAAS power train management for smooth changes in range and powershift operations
- Automatic speed matching
- Creeper gear from 140 m/h
- Fully automated gear shifting with QUADRACTIV

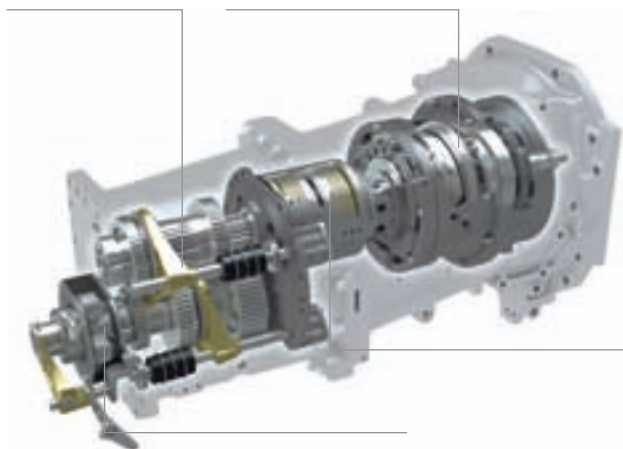

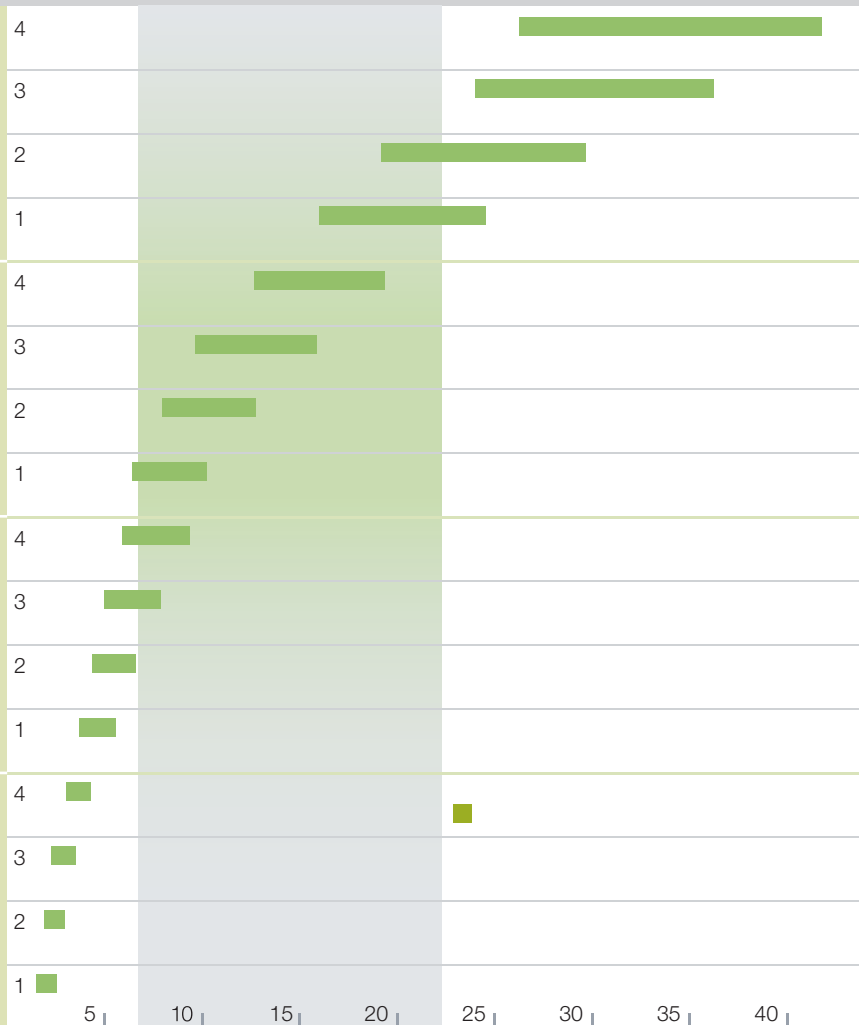
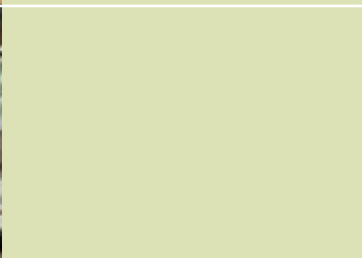
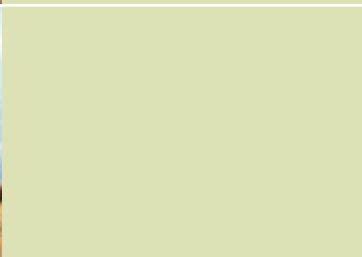
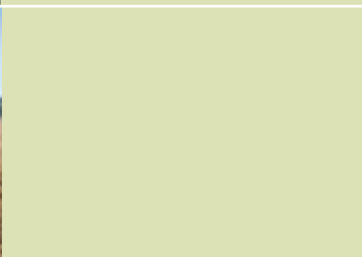
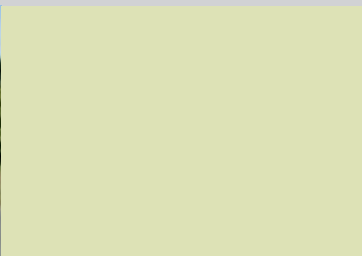



## Compact is good!

Negotiating low barn entrances, shifting straw bales, pulling and lifting heavy tillage machinery – the ARION 400 demonstrates the full efficacy of its compact and intelligent design.

Thanks to the extended wheelbase with a short overall length, the ARION 400's enormous manoeuvrability is a crucial advantage. Whether with or without CLAAS front linkage and front loader, its manoeuvrability is unimpaired, since the tractor was designed with these options in mind.

This means the tractor is extremely versatile and effective under any conditions – always and everywhere.





### Benefits of the long wheelbase and ideal weight distribution.

- Excellent stability with front loader or with attachments at the rear
- Greater tractive power, thanks to more effective four-wheel drive
- Little extra ballasting required
- Minimal front or rear ballasting requirements for daily applications
- Low fuel consumption
- Good for ground compaction
- Greater driving comfort
- Good and safe road handling



### Benefits of the short overall length.

- good manoeuvrability
- short trailer combination on the road
- Small overhang with front loader or front linkage
- good visibility
- good guidance of front attachment devices





Excellent stability –  
the front and rear linkage.

A sturdy connection between the tractor and attachment is essential for safe and efficient working. The linkages on the ARION 400 provide up to 6.5 tonnes lift at the rear and 2.8 tonnes at the front, and also have a long lift arc.

The rear linkage can be operated precisely and comfortably by the TCE 15 T electronic linkage control. The external control elements are also integrated into the mudguards as standard. Vibration damping and draft/position mix control also contribute to comfortable working and optimum results.

Thanks to the compact and fully integrated construction of the front linkage, the attachments have only a small overhang – and the folded-up lift arms fold flat against the front of the tractor.



## Keep up the pressure – the hydraulics.

An open hydraulic circuit with a hydraulic flow of 60 l/min is available as standard. The optional 98-l/min hydraulic circuit operates as a twin-pump system. The first pump serves the rear linkage, while a second pump provides flow to the hydraulic spool valves. This allows the ARION 400 to perform these two functions simultaneously. In addition, the entire hydraulic capacity of the two pumps can be pooled and delivered to the spool valves. Ideal for intensive front-loader operations or special hydraulic applications.

Up to four mechanical or two mechanical plus two electronic spool valves are available. The two electronic spool valves can be operated comfortably and intuitively with the electrohydraulic joystick, enabling you to keep the front hydraulics and/or front loader completely under control.

The hydraulic outlets at the rear are configured in such a way that they are easily accessible. Sturdy caps and oil spillage containers ensure that the rear of the tractor stays clean.

## The PTO.

Maximum of four PTO speeds available: 540/1000 or 540/1000/540 ECO/1000 ECO, which means you'll have the appropriate speed range for every application. ECO PTO saves on fuel and reduces noise, because you can drive with a reduced engine speed.





### Integrated construction.

The controls and loader frame are specially developed for the ARION 400. With supports going all the way to the rear axle, the tractor and front loader are capable of heavy front-loading work without limiting access to the maintenance points, or with any loss of ground clearance. The front loader consoles and the controls and lines are assembled in the factory and delivered ready for use.

### Two operating variants.

You operate the front loader on the ARION 400 using FLEXPILOT (hydraulically pilot-operated control valve) or using the electrohydraulic joystick. Both systems provide you with optimum operating comfort.

### Electrohydraulic joystick.

The unique joystick combines the operation of both the gearbox (shift up/down) and the front loader, allowing the right hand to remain comfortably on the joystick for rapid loading, while the left hand steers and operates the REVERSHIFT lever to change direction.

For infinitely variable control of maximum lifting and lowering speeds, you can change the flow rates of the electronic spool valves for the front loader conveniently in the CIS.





### Precise self-levelling linkage.

Six front loader models are available for the ARION 400 ex factory – the FL series with hydraulic parallel guidance and the FL C series with mechanical parallel guidance.

ARION		FL 120 / FL 120 C	FL 100 / FL 100 C	FL 80/ FL 80 C
430 CIS		■	■	–
430		■	■	–
420 CIS		■	■	–
420		■	■	–
410 CIS		■	■	■
410		■	■	■
Lifting height	m	4.15	4.00	3.85

■ Available – Not available

### Secure locking mechanism.

FITLOCK, the hydraulic locking mechanism without the need for tools, enables you to connect the loader quickly and – most importantly – securely to your attachments from the comfort of your seat. The MACH quick connector enables all hydraulic and electrical connections to be made in a single action. This means the front loader can be connected or disconnected in no time at all, and the driver needs to leave the cabin only once.

### Active damping.

The SHOCK ELIMINATOR vibration damping system effectively protects the machine and driver against shocks and impacts. The SHOCK ELIMINATOR can remain activated even under full loading.











## Everything in its place.

The clearly laid-out instrument panel provides all the necessary information at a glance. The ARION 400 is characterised by its intuitive and simple operation – no training sessions or long, drawn-out explanations are necessary. Just climb on board and drive away. From one job to another, control every function effectively and intuitively. The configuration of all the control elements is perfectly matched to any application.

The TCE 15 T linkage control has been integrated into the right-hand side console, and is therefore in an ideal position for controlling the rear attachments. Using a large rotating wheel, the working depths can easily be set and the mounted implements can be securely coupled and detached.

The external control for the rear linkage is easily accessible at both rear mudguards and is precise, just like the external control for the PTO, coming into its own with slurry tanker operators.

## Full and intuitive control.

The gear lever has had its day. The QUADRISHIFT transmission is operated effortlessly via "+/-" buttons and the shift key on the hand throttle. In the ARION 400 CIS, you can also switch between all four ranges and powershift speeds via a toggle switch on the joystick. The clutch pedal is now required for manoeuvring only, and no longer for acceleration.





## Field and transport mode.

Via a switch in the right-hand console, you can switch between the two transmission modes "Field" and "Transport".

- Field mode: shift between the powershift speeds at the push of a button, shift between ranges with +/- button and shift key.
- Transport mode: shift between all ranges and powershift ranges at the push of a button.

In the ARION 400 CIS, the QUADRACTIV automatic transmission performs the shifts. You can select your driving style conveniently in the onboard computer.

Greater comfort makes you more productive.

Three factors were crucial for CLAAS engineers in developing the new cabin:

- Tractor drivers work very long days
- A good all-round view is essential in order to be able to move attachments safely and comfortably
- A comfortable working environment is a healthy one

On the basis of these criteria, CLAAS has developed a quiet and spacious cabin in which you can work in a relaxed and productive manner, enjoy a cold drink, or calmly carry on a telephone conversation with the hands-free system integrated into the radio.





## Greater comfort means greater efficiency.

- Narrow and low bonnet for a good forward view of the front loader and front linkage
- New rear mudguard design for maximised mud-catching ability, while providing an optimum view of both sides and of the rear linkage
- Good view of the pick-up hitch
- Safe and comfortable entry in daily use, thanks to the wide-opening doors, ergonomic handles and self-cleaning steps
- Wide FOPS transparent sunroof for an unimpeded view of the front loader
- Pivoting seat with low-frequency air suspension
- Comfortable passenger seat with seatbelt
- Plenty of stowage space and practical storage compartments
- Refrigerator for bottles up to 1.5 l
- MP3 radio with Bluetooth function
- Highly efficient air conditioning





## Quick maintenance.

Even daily maintenance activities should be as straightforward as possible – experience alone tells us that nobody enjoys performing complicated or inconvenient tasks.

- The oil-level check can be made with the bonnet closed
- The one-piece bonnet is easy to open with one hand
- The entire engine space is completely exposed when the bonnet is open
- A quick pull of the latch and a hydraulic ram holds the cooling pack open
- The cooling pack stays open so that you can clean the radiator with ease
- Daily maintenance points such as the engine air filter can be accessed quickly and without the use of tools

Simple maintenance options coupled with long maintenance intervals reduce your downtime and costs.





### Simple maintenance.

The interior trim of the cabin is made of dirt-repellent, tough and easy-care material that can be cleaned quickly and easily. You can wash the floor with ease, thanks to a carefully designed mat.

### Large fuel tank.

The large fuel tank of the ARION 400 minimises tank-filling downtime. With a capacity of 175 litres, it ensures long, productive days.



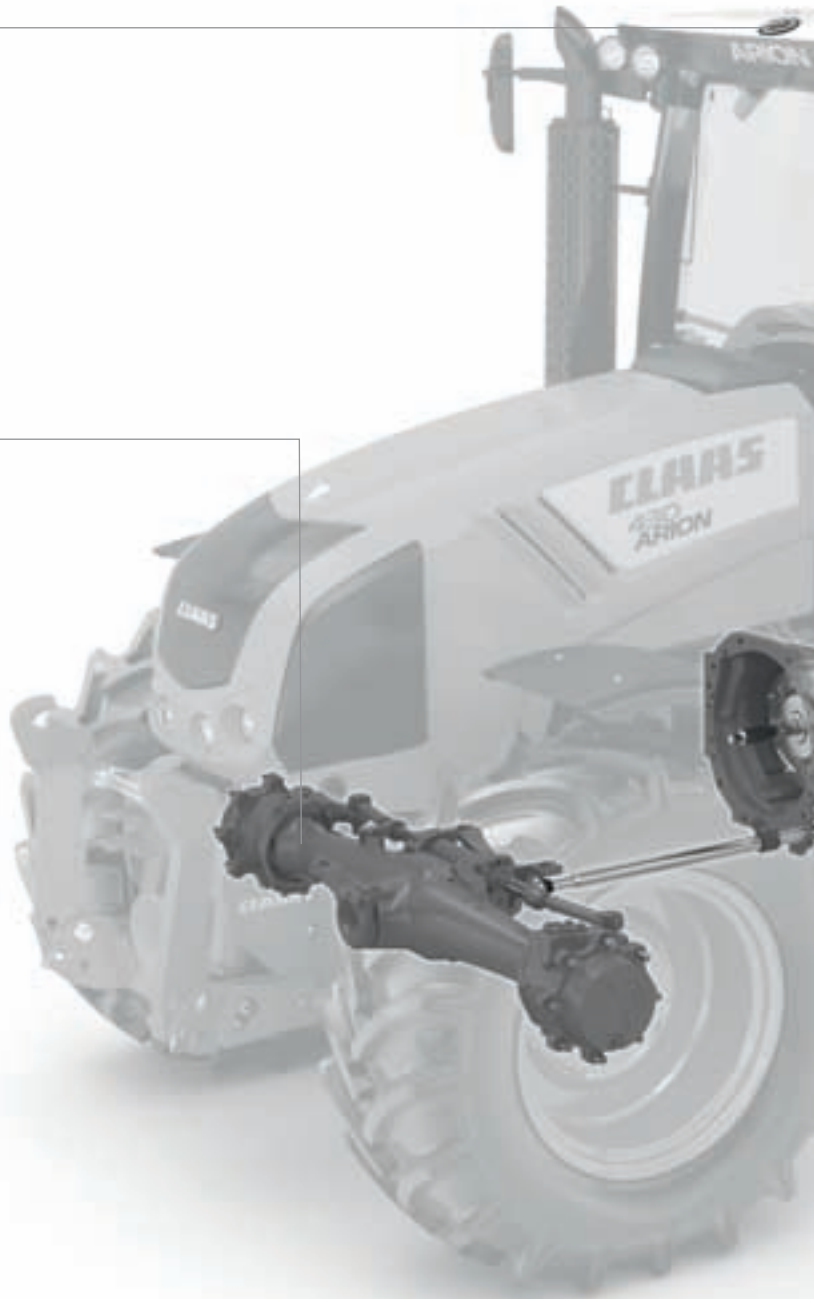

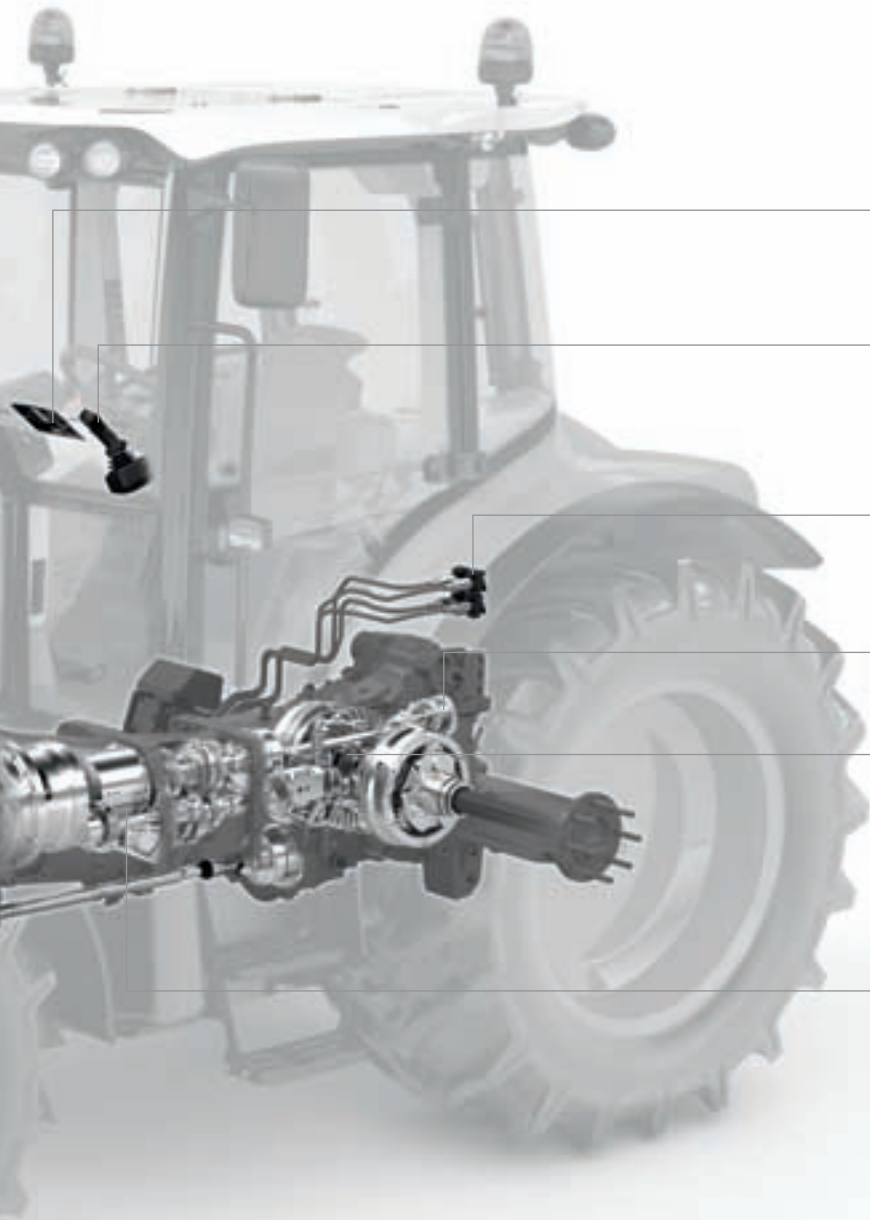





## The ARION 400 CIS.

In the compact ARION 400, you'll profit from the technology of its big brothers. With the CLAAS INFORMATION SYSTEM (CIS), the ARION 400's outstanding features provide you with a maximum of CLAAS comfort.

With CIS, simultaneously activating keys or levers in difficult manoeuvres is a thing of the past. CIS makes your life easy – by being able to adjust settings such as transmission progressivity, QUADRACTIV auto shifting, and by setting flow rates and timers on electronic spools, you are saving time. ARION 400 – enjoy efficient and productive days – day in, day out.

## Clear CIS display.

The CIS display is located on the instrument panel within your field of vision, and can be easily set by means of a rotary dial and the ESC key. The easy menu navigation and the logical symbols make operation easy. You can conveniently match all automatic functions to the working conditions and driver preferences at any time.

ARION 400	CIS	Standard
CLAAS POWER MANAGEMENT CPM	●	-
CIS in instrument panel	●	-
Automatic PTO engagement/ disengagement	●	-
98 l/m hydraulic pump	●	○
External operation of rear PTO	●	○
Reinforced rear lifter with max. 6.5 t lifting capacity	●	○
Joystick	○	-
QUADRACTIV	○	-

● Standard ○ Optional – Not available

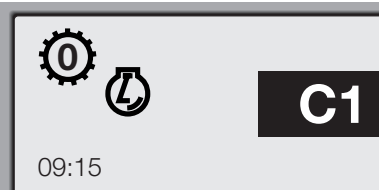
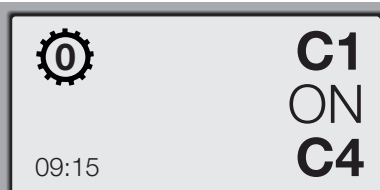



### Settings via CIS.

- QUADRACTIV power shift shifting points
- Starting gear of QUADRISHIFT transmission
- Progressiveness of REVERSHIFT clutchless reverser
- Time and flow rate settings for the electronic spool valves on the joystick
- On-board computer functions such as acreage covered, work rates, fuel consumption and remaining work time
- Display of the maintenance intervals



## Fatigue-free driving.

QUADRACTIV can be adapted to suit any driver and situation, thanks to four different transmission settings. You can select the driving mode at the push of a button in the B pillar.

The ARION 400 does exactly what you want it to, driving comfortably and safely. There won't be any unwelcome surprises, because everything can be set according to your wishes. In addition, the automatic mode optimises productivity and the fuel consumption of the tractor.

With QUADRACTIV, you can concentrate on the essentials and leave your right hand free for other tasks. If the situation requires, drivers can also intervene at any time with the +/- buttons.

## Individual programming.

With the CIS display, the following functions of the QUADRACTIV gearbox can be matched to individual driver requirements and operating conditions:

- Driving mode: field or road
- QUADRACTIV automatic gear-shifting: fully automatic mode or rev band shifting point according to driver preference
- Starting gear when starting the engine
- Starting gear with QUADRACTIV activated
- REVERSHIFT progressivity
- Disengagement of forward/reverse ratio

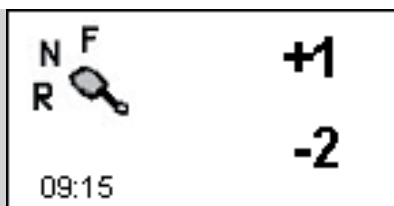

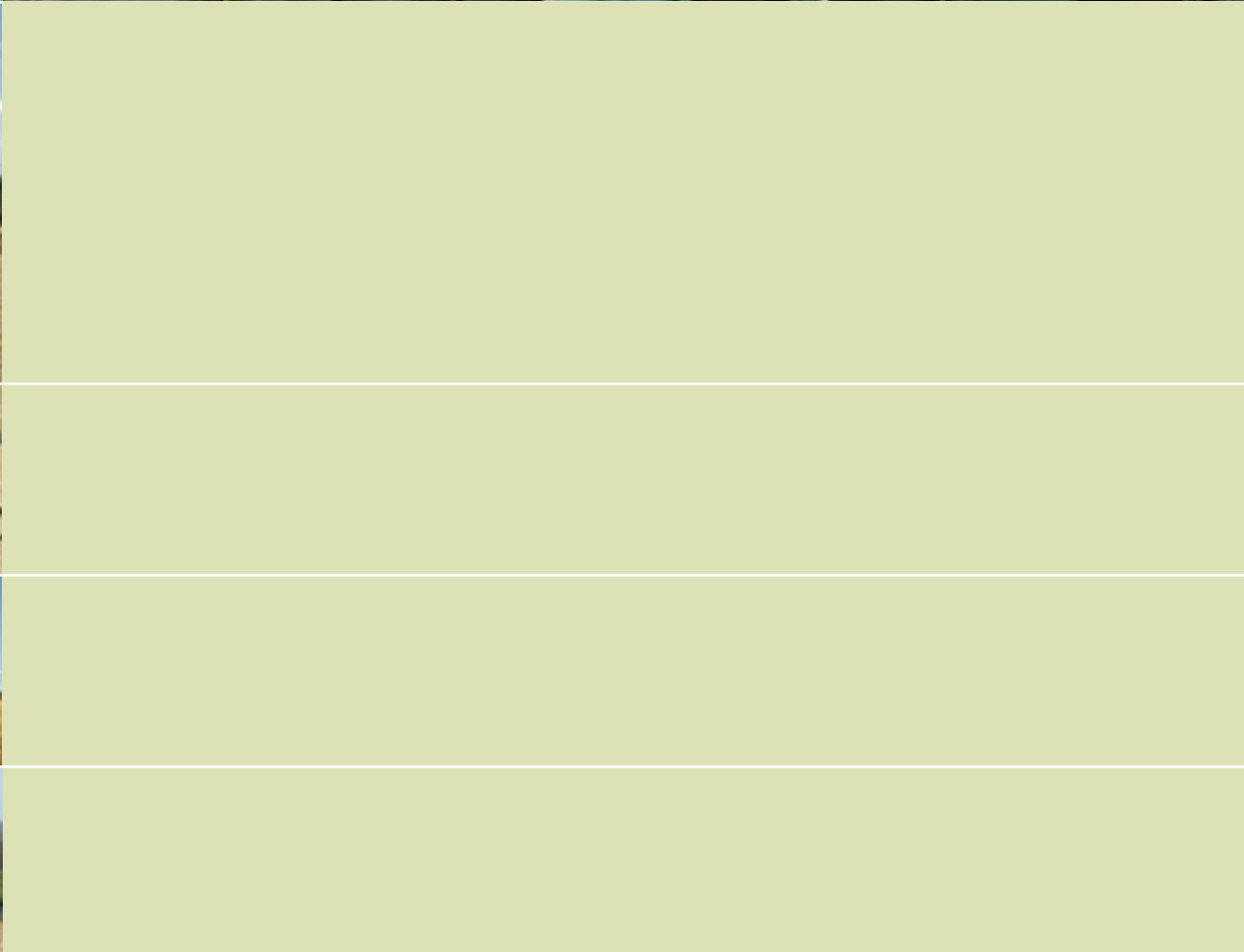

09:15

**AUTO**



## Faster at headlands.

As an experienced manufacturer of agricultural machines, CLAAS knows how important your time is, and also appreciates the value of concentration in field operations. To make your daily work easier, we have developed simple and rational automatic functions.

All automatic functions can be easily adapted to every application and conveniently operated. The driver works in a relaxed, stress-free and precise fashion. This saves time at headlands and optimises work processes every day out in the field.

Additionally, the mechanical elements such as the differential lock are protected, and tyre wear is reduced, keeping costs and downtime to a minimum.

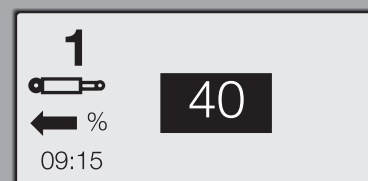
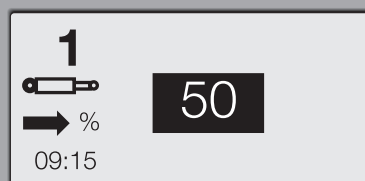
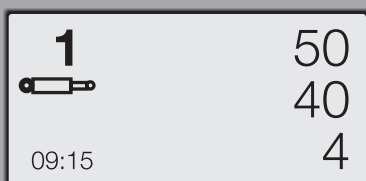



The ARION 400 offers the following automatic functions:

- Automatic PTO controlled according to rear linkage position; ideal when combination drilling with power harrow
- Automatic activation and deactivation of differential lock according to rear linkage position; ideal when ploughing
- Time and volume control of two electronic spool valves operated via the joystick
- Automatic activation and deactivation of four-wheel drive, depending on travel speed



1  
🔧  
🕒 sec  
09:15

4

## Precise working.

The joystick in the ARION 400 is ideally positioned, integrated into the armrest of the driver's seat. This removes the need for arm movement between the seat and joystick, and complete control is guaranteed at all times.

This means that two electronic spool valves can be operated via the joystick.

The QUADRISHIFT gearbox, too, can be easily operated using the rocker switch on the joystick. Alternating between gear-shifting and activating the hydraulics is no longer necessary, providing considerable benefits for front-loader work, mowing with a front/rear combination or trailed mowers, and for seed drilling.

■ Tip front attachment

■ Lower and raise front loader or front linkage





## Many functions.

Two electronic spool valves can be operated proportionally with the joystick. There is the option of using these spool valves to supply the front loader, the front linkage and a connection to the tractor rear, when the front is not being used.

The flow rates of the two spool valves and also the timer control can be easily set in the CIS, so that lightly tapping the joystick is sufficient to reach the full travel of the hydraulic cylinders.







### Working to the nearest centimetre.

When it's important to avoid overlapping or damage to already standing crops, good drivers achieve a high degree of accuracy. However, even the best of them can suffer fatigue or loss of concentration.

CLAAS's guidance systems assist you during your work in the field or on grassland, which means that precision to the nearest centimetre is no longer rocket science.

- Make every track exactly the same as the previous one
- Make full use of the working width
- Reduce overlapping
- You minimise damage to existing plant stands or row crops
- Save valuable operational time, or extend it into the night-time hours
- Optimise the cost-efficiency of all your working processes

### Correction signal as required.

CLAAS has set up its range of systems in such a way that you can flexibly extend them at any time. This applies just as much to the terminal technology as to using any of today's essential correction signals. All systems can also be retrofitted to the ARION 400.





## GPS PILOT RTK

- Accuracy +/- 2 to 3 cm
- Up to 20 km coverage
- No licence fees
- Maximum steering precision
- Reference signal can be set by the local dealer
- For machinery fleets or outsourcing

## GPS PILOT Baseline HD

- Accuracy +/- 4 to 6 cm
- Farm has its own mobile reference station
- Range 3-5 km
- Public reference signal
- Reference station can be used by more than one machine at the same time

## Omnistar HP GPS PILOT

- Accuracy +/- 5 to 10 cm
- DGPS dual frequency
- Correction signal received by satellite
- Quarterly or annual licence costs for the reference signal

## COPILLOT

- Accuracy to within +/- 15–30 cm
- EGNOS satellite signal
- No licence fees
- Manual guidance

## CAM PILOT

- 3D camera mounted on the front of the tractor
- Accuracy +/- 5 cm
- Steering hydraulics can be combined with the GPS PILOT
- Tractor follows the rows of plants, tramlines, furrows or swaths

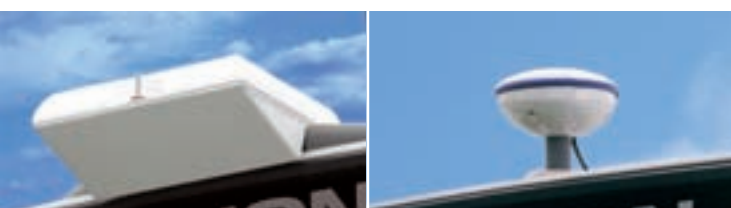

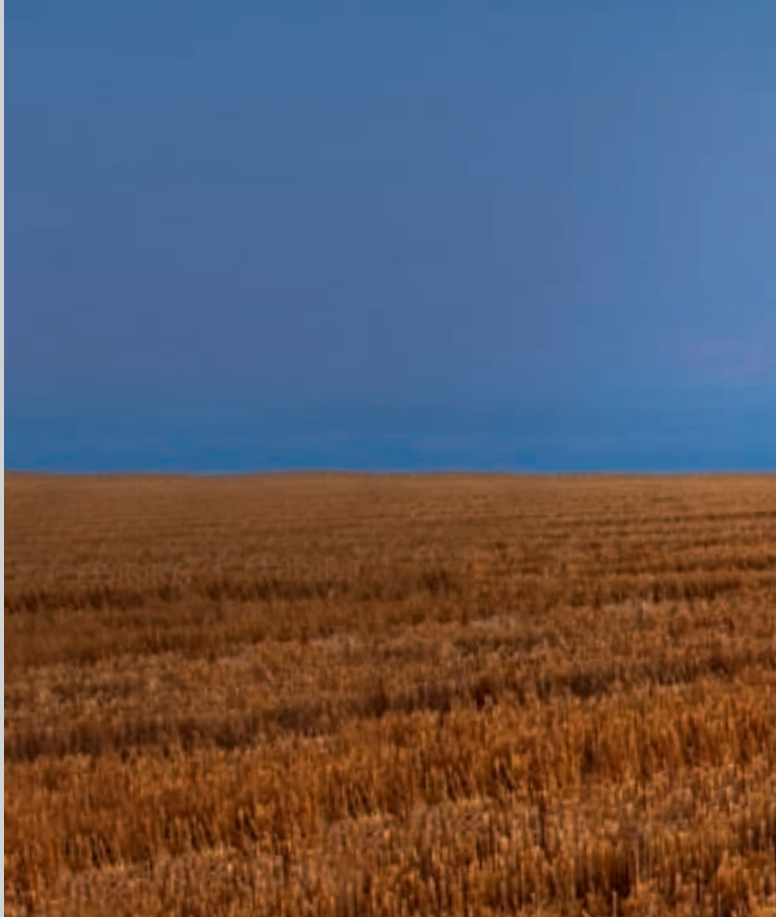
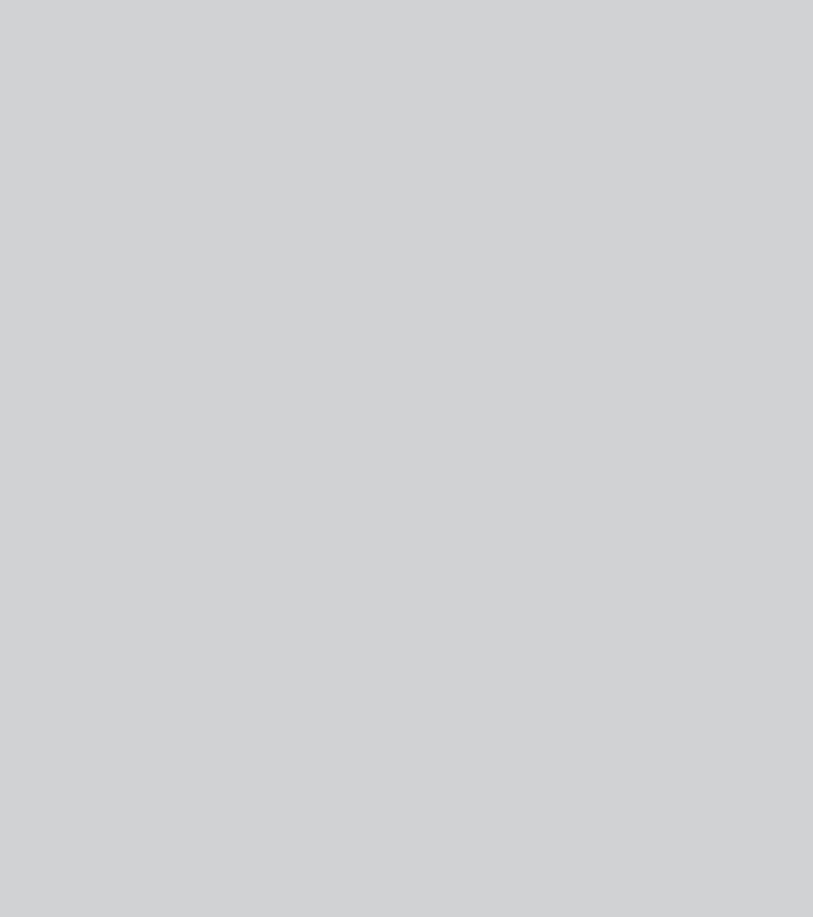

## FIRST CLAAS SERVICE® around the clock.

Our many years of experience and enormous knowledge base have familiarised us like no one else with the working methods and individual requirements of every farming business. So we know exactly what it all comes down to, including the service aspects. Our FIRST CLAAS SERVICE® package is synonymous with absolute reliability and professionalism. Or, to put it simply: we're there for you right away when you need us. That goes for the ARION 400 just as it does for all other CLAAS machines.



## Rest assured.

We are dedicated to supplying the ORIGINAL CLAAS spare parts you require whenever you need them. Our service is extremely well organised and proven over many years around the globe. We endeavour to do our utmost to minimise potential downtime, because we know as well as you do that time is money.

## Committed teams.

Our highly trained service teams thoroughly enjoy their work and understand the issues perfectly, since expert knowledge and commitment are essential to successful teamwork. You will therefore always remain the kind of customer we're glad to have – completely satisfied.

## Cost-conscious investment in efficiency is a recipe for success.

The individual CLAAS MAXI CARE® service packages offer the highest level of safety for all CLAAS products.

Attention to proper service means increased reliability. We provide a flexible selection of modules such as extended warranty to keep costs on track and transparent.

There are customised options and combinations for your CLAAS machine:

- Service contract maintenance services at a fixed price in accordance with the operator's manual
- MAXI CARE® warranty extension

Ask your authorised CLAAS dealer for more information.





Convincing reasons for everybody.

# ARION

		430 CIS	430	420 CIS	420	410 CIS	410
<b>Dimensions</b>							
Rear wheels		18.4 R 38	18.4 R 38	18.4 R 34	18.4 R 34	16.9 R 34	16.9 R 34
Front wheels		14.9 R 28	14.9 R 28	14.9 R 24	14.9 R 24	13.6 R 24	13.6 R 24
<b>Height</b>							
Overall height (a)	mm	2811	2811	2761	2761	2736	2736
Centre of rear axle – top of cab (b)	mm	1986	1986	1986	1986	1986	1986
<b>Length</b>							
Wheelbase (c)	mm	2564	2564	2564	2564	2564	2564
Length (without front weight) (d)	mm	4442	4442	4442	4442	4442	4442
<b>Ground clearance</b>							
Front axle (e)	mm	516	516	466	466	441	441
Rear axle (f)	mm	505	505	455	455	430	430
<b>Weight</b>							
Rear wheels		18.4 R 38	18.4 R 38	18.4 R 38	18.4 R 38	16.9 R 38	16.9 R 38
Front wheels		14.9 R 28	14.9 R 28	14.9 R 28	14.9 R 28	13.6 R 28	13.6 R 28
Weight without ballast	kg	4900	4900	4900	4900	4800	4800
Max. front ballast	kg	722	722	722	722	722	722
Weight distribution with ballast (rear/front)	%	50/50	50/50	50/50	50/50	49/51	49/51
Max. permissible total weight	kg	8800	8800	8800	8800	8800	8800

		430	420	410
<b>Tyres</b>				
Rear tyres	Front tyres			
16.9 (420/85) R 34	13.6 (340/85) R 24	□	□	□
480/70 R 34	380/70 R 24	□	□	□
540/65 R 34	440/65 R 24	□	□	□
480/75 R 34	380/75 R 24	□	□	□
18.4 (460/85) R 34	14.9 (380/85) R 24	□	□	□
520/70 R 34	420/70 R 24	□	□	□
600/65 R 34	480/65 R 24	□	□	□
18.4 (480/80) R 34	14.9 (400/80) R 24	□	□	□
13.6 (340/85) R 38	11.2 (280/85) R 28	□	□	□
16.9 (420/85) R 38	13.6 (340/85) R 28	□	□	□
480/70 R 38	380/70 R 28	□	□	□
540/65 R 38	440/65 R 28	□	□	□
18.4 (460/85) R 38	14.9 (380/85) R 28	□	□	□
600/65 R 38	480/65 R 28	□	□	□
520/70 R 38	420/70 R 28	□	□	□
520/75 R 38	420/75 R 28	□	□	□
600/60 R 38	480/60 R 28	□	□	□
650/60 R 38	520/60 R 28	□	–	–
16.9-34 <sup>1</sup>	14.9-24 <sup>1</sup>	□	□	□
18.4 (480/80) R 34 <sup>1</sup>	14.9 (400/80) R 24 <sup>1</sup>	□	□	□
18.4 (480/80) R 38 <sup>1</sup>	14.9 (400/80) R 28 <sup>1</sup>	□	□	□

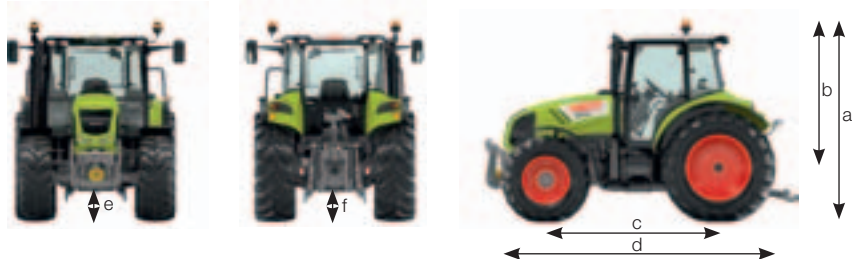

□ Available <sup>1</sup> Tyres with industrial tread.



CLAAS UK  
Saxham  
Bury St. Edmunds  
Suffolk  
IP28 6QZ  
Tel 01284 763100  
claas.co.uk  
info-uk@claas.com  
333012131111 CR DC 0112

