

MUNICIPALITY

56 to 340 hp



CASE IH
MUNICIPALITY



HIGH EFFICIENCY
LOW COSTS

INTRODUCTION

THE SERIES FOR EXPERTS

Municipal work, ground care and industry are three sectors with very specific requirements. At Case IH we have the answer: nine solutions designed especially for these expert sectors based on our new tractor ranges, from the flexible Quantum V/N/F Series to our flagships Puma and Magnum. The Case IH tractors in the experts' range are tailored to the requirements of municipal work, ground care and industry, and can be fitted with a variety of implements and tyres to match the demands of every application. All these models share the Case IH tradition of safety, operator comfort and technological advantages.



MUNICIPAL

With Case IH, you can manage the full spectrum of municipal maintenance jobs, from green verge mowing to street cleaning, from waterway maintenance to snow clearing in the winter months. A wide variety of implements, from double drum rotary snow ploughs to branch shears for hedges, can be mounted to the front and back of our tractors or on the Case IH municipal frame for added stability and safety.



GROUND CARE

Managing parkland and extensive grounds is easy with Case IH. Our tractors can be adapted to carry out a wide variety of ground care applications, from mowing, aerating and scarifying extensive lawns to mowing large areas and horticultural jobs.



INDUSTRY

Case IH tractors also offer an ideal solution for a number of construction, material handling and transport applications. Combined with a dump truck or tipper, they can transport and unload large volumes of material efficiently, while fitted with a crane they make pipe-laying jobs easy. Case IH offers the right solution to perform all tasks effectively and cost efficiently.

OPTIMUM EFFICIENCY



SPECIFIED SOLUTIONS BY CASE IH

Every Case IH tractor – from the Quantum V/N/F to the Magnum – has its own particular strengths that guarantee optimum efficiency for the task in hand. Tailored to the requirements of municipal work, ground care and industry, they can be fitted with a variety of implements and tyres to meet the demands of each application. They all share the tradition of safety, the level of comfort drivers have come to expect and the technological advantages offered by Case IH.



MUNICIPAL

	Quantum V/N/F	Farmall C	Farmall U and Farmall U PRO	Maxxum	Maxxum Multicontroller	Puma	Puma CVX	Magnum
WINTER DUTIES snowplough, snow blower, gritter	•	•	•	•	•	•	•	
ROAD MAINTENANCE grass verge mower, hedge / branch cutter	•	•	•	•	•	•	•	
CLEANING sweeper, weed brush, washing brush	•	•	•	•	•	•	•	
RIVER AND LAKE MAINTENANCE mowers and mulchers with boom, ditch cleaning machines, flail mulchers		•			•	•	•	•



GROUND CARE

	Quantum V/N/F	Farmall C	Farmall U and Farmall U PRO	Maxxum	Maxxum Multicontroller	Puma	Puma CVX	Magnum
MOWING PARKS / GROUNDS disc mowers, rotary mowers, flail mowers	•	•						
GROUND CARE scarifier, lawn aerator, seed drill	•	•	•					
LARGE-AREA MOWING rotary mowers, flail mowers		•	•	•	•	•	•	
HORTICULTURAL CARE front loader, rear digger, trailer, 3-point linkage box	•	•	•	•	•	•	•	



INDUSTRY

	Quantum V/N/F	Farmall C	Farmall U and Farmall U PRO	Maxxum	Maxxum Multicontroller	Puma	Puma CVX	Magnum
CONSTRUCTION tipper, dozer blade						•	•	•
MATERIAL HANDLING pushout trailer, front loader				•	•		•	•
INDUSTRIAL CONSTRUCTION crane, front loader, dump trailer			•	•	•	•	•	•
TRANSPORT low loader, tipper			•	•	•	•	•	•



NARROW BY DESIGN, **POWERFUL BY NATURE**

QUANTUM V/N/F SERIES



A QUANTUM FOR EVERY OPERATION

When you look for specialists in municipal duties, 13 different models in the Quantum range mean just one thing: there will always be the right machine for the tasks at hand. 65 to 106hp rated power deliver excellent performance when work such as sweeping or snow-blowing has to be performed on pavements and other narrow terrain. Similarly and due to its light weight, Quantum tractors offer excellent performance for maintenance work on lawns and sports grounds. They are a superb choice for any type of facility management.

CONFIGURATIONS TO SUIT YOUR APPLICATION

Quantum V is the obvious choice on narrow sites whilst **Quantum N** gives more stability when width is less critical. **Quantum F** provides more operator space and a wider vehicle for ground care use. In addition, cab or platform versions can be specified to tailor a tractor from the Quantum specialty range to suit your exact operating conditions.

A QUANTUM OF COMFORT AND CONTROL

You can easily access the comfort of your Quantum cab through the wide opening doors. Once in position, you will take full control with the intuitively positioned controls and clear instrumentation. The slim cab pillars and rear view mirrors ensure you always have a clear view of your working implements or following sprayers.

SUPERB MANOEUVRABILITY

The Quantum is a true match for any municipal challenge. For all tasks in tight spaces, just rely on the 57° steering angle, the electro-hydraulic 4WD and the engagement of the diff-lock: the manoeuvrability of the Quantum range is more than impressive. These tractors offer optimum handling along with powerful brakes and automatic 4WD-systems for efficient traction and safety.

LIGHTWEIGHT TRACTOR WITH LOTS OF POWER

You can choose from three mechanical and three Powershuttle transmissions to customise your Quantum tractor according to the needs of your operation. The precision transmissions are designed and built for smooth and reliable heavy-duty operation year after year, and for the speed and the traction required on the job. For PTO operations, up to three speeds (540 / 540E / 1,000) and an additional ground speed option are available for optimum power and economy.

HIGH CAPACITY HYDRAULICS

Rear linkage 63.8l/mn (std. 48.6l/mn) hydraulic oil flow ensures constant maximum power to the implement. Up to 2,600kg lift capacity, Mechanical or Electronic Hitch Control with draft sensing and up to 3 rear remote valves and 2 midmount valves.



MODEL	QUANTUM 65 V	QUANTUM 75 V	QUANTUM 85 V	QUANTUM 95 V	QUANTUM 105 V	QUANTUM 75 N	QUANTUM 85 N	QUANTUM 95 N	QUANTUM 105 N	QUANTUM 75 F	QUANTUM 85 F	QUANTUM 95 F	QUANTUM 105 F
Number of cylinders / capacity (cm ³)	4 / 3,200	4 / 3,200	4 / 3,200	4 / 4,500	4 / 4,500	4 / 3,200	4 / 3,200	4 / 4,500	4 / 4,500	4 / 3,200	4 / 3,200	4 / 4,500	4 / 4,500
Rated engine power ECE R120 ¹⁾ (kW/hp)]	48 / 65	57 / 78	65 / 88	71 / 97	78 / 106	57 / 78	65 / 88	71 / 97	78 / 106	57 / 78	65 / 88	71 / 97	78 / 106
Min. length / width / height (mm) ²⁾	3,692 / 1,080 / 2,145	3,692 / 1,080 / 2,145	3,779 / 1,200 / 2,190	3,779 / 1,200 / 2,190	3,779 / 1,200 / 2,190	3,692 / 1,305 / 2,235	3,692 / 1,305 / 2,235	3,779 / 1,530 / 2,250	3,779 / 1,530 / 2,250	3,682 / 1,398 / 2,273	3,682 / 1,398 / 2,273	3,769 / 1,398 / 2,273	3,769 / 1,398 / 2,273

¹⁾ ECE R120 correspond to ISO 14396 and 97/68/EC

²⁾ All dimensions related to standard tyres

SMALL ON THE OUTSIDE, **BIG ON THE INSIDE**

FARMALL C SERIES



VERSATILE AND ECONOMICAL

The Farmall C is the most versatile and economical way to get to know the Case IH Farmall range. It is ideally suited to flexible operating conditions and produces a convincing mowing performance as well as being perfect for maintaining paths and roads, even in winter. Extremely economical, lightweight and manoeuvrable, but at the same time spacious, powerful and reliable, the Farmall C is the perfect all-rounder. Simply the ideal machine for tending landscaped parks, sports grounds and golf courses.



THE PERFECT WORK STATION

The new cab is designed for comfort and productivity: the comfortable seat, ergonomic controls layout and quiet operation will leave you refreshed at the end of a long day's work; the excellent surround vision and high visibility roof window will make your day more productive; the flat floor and the wide doors for easy entry and exit will make it easy to run errands.



SMALL TRACTOR, BIG PERFORMER

You are never short of power on a Farmall C, with its rear linkage lifting power exceeding 3,500kg, external ram option and dedicated pump for the external hydraulic circuit. You can work with a full range of implements, as hydraulic flow can be directed as needed by a choice of Mechanical or Electronic Hitch Control, up to three rear and two midmounted hydraulic remote valves.



THE RIGHT TRANSMISSION TO MEET YOUR NEEDS

You can choose between the simplicity of manual gear selection or low effort hydraulic operation. The assertive mechanical transmission offers 12 forward and 12 reverse gears with 40kph, and is also available with Powershuttle. An optional creeper gearbox allows you to achieve slow working speeds. The top three models of the range are also available with a two-speed Powershift that doubles the number of available speeds to 24 forward and 24 reverse, plus Powerclutch and Powershuttle. With the new transmissions on Farmall tractors, you get higher power ratings and the option of bigger tyre configurations.

MODEL	FARMALL 55 C	FARMALL 65 C	FARMALL 75 C	FARMALL 85 C	FARMALL 95 C	FARMALL 105 C
Number of cylinders / capacity (cm ³)	4 / 3,200	4 / 3,200	4 / 3,200	4 / 3,400	4 / 3,400	4 / 3,400
Rated engine power ECE R120 ¹⁾ (kW/hp)	41 / 56	48 / 65	55 / 75	63 / 86	73 / 99	79 / 107
Min. length / width / height (mm) ²⁾	3,789 / 1,922 / 2,420	3,789 / 1,922 / 2,420	3,789 / 1,922 / 2,420	4,247 / 1,923 / 2,610	4,247 / 1,923 / 2,610	4,247 / 1,923 / 2,610

¹⁾ ECE R120 correspond to ISO 14396 and 97/68/EC

²⁾ All dimensions related to standard tyres

SPECIFIED TO YOUR APPLICATION

FARMALL U SERIES



THE VERSATILE MULTI-PURPOSE TRACTOR WITH YEAR ROUND CAPABILITY

The three Farmall U models ranging from 99 to 114hp are hard working heavy-duty tractors that combine a tough performance with full deluxe features and comfort. These powerful and versatile tractors have the high-capacity hydraulics to handle any application, and will live up to the legendary Farmall reputation in all jobs with mounted machinery, trailed equipment or on transport duties. They are powerful enough to cope with the demands of winter service, drive numerous machines and work with front loader systems and road maintenance equipment.

Efficient Power. The Farmall U run on proven FPT common rail engines that meet Stage III B emissions standards with the addition of an after-treatment system and deliver fast acceleration, more torque and constant maximum power between 1,900 and 2,300rpm.

All day comfort. The spacious air-conditioned cab with fully adjustable driver seat and steering column, and folding passenger seat with safety belt provides a comfortable working environment. The 5.2m² glazed area and A-pillar exhaust ensure excellent all-round visibility, while the steering-column mounted instrumentation puts you in full control for stress-free operation.

High-capacity hydraulics. An EHC (Electronic Hitch Control) is standard. With a choice of up to three rear and two midmounted hydraulic remote valves, hydraulic flow can be directed as required to control a wide range of municipality and ground care equipment. At the rear linkage, there's maximum 5,400kg (OECD) of lifting power.



MODEL	FARMALL 95 U	FARMALL 105 U	FARMALL 115 U
Number of cylinders / capacity (cm ³)	4 / 3,400	4 / 3,400	4 / 3,400
Rated engine power ECE R120 ¹⁾ (kW/hp)	73 / 99	79 / 107	84 / 114
Min. length / width / height (mm) ²⁾	4,161 / 2,100 / 2,673	4,161 / 2,100 / 2,673	4,161 / 2,100 / 2,673

¹⁾ ECE R120 correspond to ISO 14396 and 97/68/EC

²⁾ All dimensions related to standard tyres

PROUD TO DRIVE PREMIUM

FARMALL U PRO SERIES



STRONG, ROBUST AND TAILOR-MADE

Made in Austria, the three Farmall U PRO models ranging from 99 to 114hp offer a premium performance and deluxe comfort. With more power and torque across the range, 4-speed Powershift transmission and 4-speed PTO, they are designed to work hard and take on tough tasks in ground care, industry and municipality all year around. They are particularly well suited to PTO driven tasks, front loader work and general haulage jobs with their high power-to-weight ratio and manoeuvrability.

HIGH PRODUCTIVITY DRIVELINE

The Farmall U PRO features a 32x32 four-speed Powershift transmission with 40kph Eco capability at 1,750 engine rpm that delivers on performance and productivity, and provides a low centre of gravity. The power curve perfectly matches the 4-speed PTO (540/540E/1000/1000E), so that you always have the power you need whatever the job, from light trimming to operating with a large rotary mower.

THE COMFORT ZONE

With a low noise level of just 72db (A), full air conditioning and controls that are placed to ensure easy operation, the cab of the Farmall U PRO offers a superb operator environment. Easy to read instrumentation mounted on the steering column, an easily adjustable and comfortable driver's seat, and a comfortable passenger seat that folds out of the way to take the stress out of the longest working day.

ENVIRONMENTAL AWARENESS

Thanks to the separate reservoir, biodegradable hydraulic fluids can be used for the operation of loader and other implements.

IN CONTROL

The Case IH Multicontroller puts all the key operating functions of your Farmall U PRO at your fingertips: from transmission and shuttle to Powerclutch and rear hitch controls; even the electronic remote valves, if specified.



LOADS BETTER

Case IH LRZ loaders are the perfect match for Farmall U PRO tractors and with a lifting capability of 2,540kg, they are unbeatable.

MODEL	FARMALL 95 U PRO	FARMALL 105 U PRO	FARMALL 115 U PRO
Number of cylinders / capacity (cm ³)	4 / 3,400	4 / 3,400	4 / 3,400
Rated engine power ECE R120 ¹⁾ (kW/hp)	73 / 99	79 / 107	84 / 114
Min. length / width / height (mm) ²⁾	4,166 / 2,100 / 2,673	4,166 / 2,100 / 2,673	4,166 / 2,100 / 2,673

¹⁾ ECE R120 correspond to ISO 14396 and 97/68/EC

²⁾ All dimensions related to standard tyres



POWERFUL AND NIMBLE

MAXXUM SERIES



THE ENDURING ECONOMIC MIRACLE

The Maxxum tractor series is a high performer, with power and low fuel consumption in the municipal, ground care, landscaping and industry sectors. It's not only its range of engines and transmissions that enables the Maxxum to master every conceivable task, but its flexibility and adaptability too. Whether the job in hand is heavy duty front loading, winching, demanding mowing or snow clearing and gritting: the Maxxum shows maximum strength and endurance with optimum cost-effectiveness in every job.



POWERFUL LIFTER

With a lift capacity of up to 7,864kg, the Maxxum Efficient Power can work with the heaviest implements. The standard Electronic Hitch Control automatically adjusts the height of the hitch to the draft load and the Hitch Ride Control system absorbs the bouncing of mounted implements, enhancing your comfort and productivity. You will also appreciate the many features that make it easy to connect the tractor to the hitch and PTO quickly and efficiently.

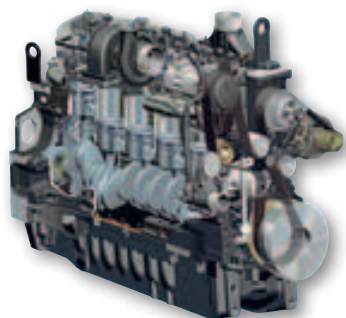

PROFITABLE PERFORMANCE

The intercooled turbo-diesel engines from 110 to 140hp comply with the EU emissions legislation for Stage III B and deliver economical performance in every application. All Maxxum models are available with a two-stage 24 x 24 Powershift transmission or a four-stage Powershift transmission 16 (17) x 16. The Powershuttle lever on the left-hand side of the steering wheel enables the tractor to change direction without operating the clutch. Automatic speed switching also provides more operating comfort.



SMOOTH RIDE

The low vibrations resulting from the top quality seat, cab suspension and front axle suspension provide a smooth ride for maximum comfort.



IMPRESSIVE TURNING CIRCLE

Due to their compact engine dimensions Maxxum tractors have an extremely tight turning radius. Dynamic Fenders, fitted as standard, give these tractors an additional 30% in steering angle for really superb handling characteristics.

MODEL	MAXXUM 110	MAXXUM 120	MAXXUM 130	MAXXUM 115	MAXXUM 125	MAXXUM 140
Number of cylinders / capacity (cm ³)	4 / 4,485	4 / 4,485	4 / 4,485	6 / 6,728	6 / 6,728	6 / 6,728
Rated engine power ECE R120 ¹⁾ (kW/hp)	81 / 110	89 / 121	96 / 131	85 / 116	92 / 125	103 / 140
Min. length / width / height (mm) ²⁾	4,292 / 2,205 / min. height 2,758 low roof; 2,878 high roof	4,292 / 2,205 / min. height 2,758 low roof; 2,878 high roof	4,292 / 2,205 / min. height 2,758 low roof; 2,878 high roof	4,532 / 2,205 / min. height 2,758 low roof; 2,878 high roof	4,532 / 2,205 / min. height 2,758 low roof; 2,878 high roof	4,532 / 2,205 / min. height 2,758 low roof; 2,878 high roof

¹⁾ ECE R120 correspond to ISO 14396 and 97/68/EC

²⁾ All dimensions related to standard tyres

TAKE CONTROL OF **YOUR PRODUCTIVITY**

MAXXUM MULTICONTROLLER SERIES





INNOVATIVE, PRODUCTIVE AND INTELLIGENT

With the Maxxum Multicontroller series repetitive operations can be simply forgotten. These are now taken over by the intelligence of the onboard automatic system that gives this tractor the highest possible productivity. Whether for snow clearing and gritting, road maintenance, front loader work or a wide variety of transport tasks, the Maxxum Multicontroller ensures the job is completed more easily and quickly than ever before. And, of course, this is coupled with maximum safety and comfort for the operator.

PERFECT RESULTS COME AUTOMATICALLY

No other universal tractor functions more easily and safely than this. The electronic gear change monitor changes gear up and down automatically with the aid of the Case IH Powershift on the load and output. The PTO management system engages or disengages the PTO automatically depending on the position of the mounted implement. The 4WD and the differential lock that can be switched under load are activated and deactivated automatically by the traction management system depending on the angle of lock and hitch position.



MODEL	MAXXUM 110 MC	MAXXUM 120 MC	MAXXUM 130 MC	MAXXUM 115 MC	MAXXUM 125 MC	MAXXUM 140 MC
Number of cylinders / capacity (cm ³)	4/4,485	4/4,485	4/4,485	6/6,728	6/6,728	6/6,728
Rated engine power ECE R120 ¹⁾ (kW/hp)	81/110	89/121	96/131	85/116	92/125	103/140
Min. length / width / height (mm) ²⁾	4,292 / 2,205 / min. height 2,758 low roof; 2,878 high roof	4,292 / 2,205 / min. height 2,758 low roof; 2,878 high roof	4,292 / 2,205 / min. height 2,758 low roof; 2,878 high roof	4,532 / 2,205 / min. height 2,758 low roof; 2,878 high roof	4,532 / 2,205 / min. height 2,758 low roof; 2,878 high roof	4,532 / 2,205 / min. height 2,758 low roof; 2,878 high roof

¹⁾ ECE R120 correspond to ISO 14396 and 97/68/EC

²⁾ All dimensions related to standard tyres



POWER WITH HIGH PERFORMANCE

On the Case IH Maxxum Multicontroller, state-of-the-art intercooled 4 and 6 cylinder turbo-diesel engines from 110 to 140hp ensure highly efficient power delivery. The common rail high pressure direct injection lends the 4-valve engines a fast response with steady power generation and maximum economy. Active Engine Management increases engine performance by up to 28hp during PTO operation and the SpeedPlus function allows one or two fixed engine speeds to be set, guaranteeing constant PTO speed irrespective of any changes to the load capacity.

PROVEN TRANSMISSION TECHNOLOGY

The multi-award-winning Case IH 4-Speed Powershift transmission changes more smoothly, precisely and efficiently than any other in this power class. The 4-Speed Powershift transmission allows changing under load and has 16/16 gears, or 32/32 with creeper gearbox. Every Maxxum Multicontroller tractor is available with an optional 17th gear that enables fast driving on roads at up to 50kph or saving fuel at 40kph with the latest ECO transmission.



THE ULTIMATE OPERATOR INTERFACE

You hold all the tractor's key functions in the palm of your hand on the Maxxum Multicontroller's armrest with intuitive control panel and integrated Multicontroller lever. The instrument panel mounted on the A-post provides you with all the information you need on the tractor's performance at a glance.

LUXURIOUS COMFORT

The Maxxum Multicontroller's spacious cab provides a well-planned work station with perfect visibility. You can work long days with minimal fatigue in the quiet cab: with noise levels of just 71 dB(A), it's quieter than your car!

Enjoy the healthiest and most comfortable driving posture with the fully adjustable seats with lumbar support, optional low frequency seat with heating, and adjustable steering wheel.

The sloping hood, "A" post-mounted exhaust, sculpted body and full length glazed doors places the whole working area in your field of vision. The Maxxum Multicontroller series also features a roof window, ideal for roadside maintenance work.

POWERFUL ALL-WHEEL BRAKING

The Maxxum Multicontroller features heavy duty, maintenance-free, oil immersed disc brakes. Additional front brakes are available as an option to provide all-wheel braking. This allows for increased safety and efficiency during all road transport tasks.



MULTI-PURPOSE EFFICIENCY **DELIVERS HIGH RETURNS**

PUMA SERIES



ALL-ROUND EFFICIENCY

With 7 models ranging from 131 to 215hp, the efficient multi-purpose Puma tractors provide you with just the right of amount of power you need for efficient mowing applications, such as operating a tandem mower. You can rely on these tough, powerful and fuel efficient tractors, made in Austria, to deliver consistently high returns.

FUEL-SAVING

With best-in-class fuel consumption and up to 47% torque rise, Puma tractors deliver a massive performance with a frugal fuel consumption. When Power Management is switched on, the Puma reaches maximum torque at just 1400 to 1600rpm. Lower engine speed means you can work more quietly, but even more importantly, you save fuel - and money.



SPACIOUS COMFORT CAB

Enjoy a comfortable ride in the quietest and biggest cab in this class with ergonomically designed armrest controls, and keep track of the machine's status with the A-pillar instrumentation. Case IH gives you the highest level of protection and ease of operation for a full day of productivity and enjoyment out on the road, at the airport and around the yard.



FULL POWERSHIFT TRANSMISSION

The only one in the market, providing seamless smooth shifting to 40 or 50kph without torque interruption.

HYDRAULICS FOR PRECISION POWER

The Puma features best-in-class hydraulics with a hitch lift capacity of up to 10,460kg. The hydraulic system is powered by a variable displacement piston pump delivering up to 150 litres per minute for extremely responsive operation of on-board systems and remote-controlled machinery. Up to 9 remote valves can be supplied. Case IH LRZ front loaders are available factory fitted on the Puma 130, 145 and 160 models, delivering maximum lift up to 2800kg and maximum height at pivot up to 4260mm.



NIMBLE OPERATOR

The compact engine dimensions give the Puma an exceptionally tight turning radius, while the standard Dynamic Fenders add 30% to the steering angle.

MODEL	PUMA 130	PUMA 145	PUMA 160	PUMA 170	PUMA 185	PUMA 200	PUMA 215
Number of cylinders /capacity (cm ³)	6/6,728	6/6,728	6/6,728	6/6,728	6/6,728	6/6,728	6/6,728
Rated engine power ECE R120 ¹⁾ (kW/hp)	96/131	107/146	118/160	123/167	136/185	147/200	158/215
Min. length / width / height (mm) ²⁾	4,719 / 2,470 / 3,070	4,719 / 2,470 / 3,070	4,719 / 2,470 / 3,070	5,017 / 2,682 / 3,090	5,017 / 2,682 / 3,090	5,017 / 2,682 / 3,090	5,017 / 2,682 / 3,090

¹⁾ ECE R120 correspond to ISO 14396 and 97/68/EC

²⁾ All dimensions related to standard tyres

SIMPLICITY THAT PAYS YOU MORE

PUMA CVX SERIES



PUSHING THE BOUNDARIES OF POSSIBILITY

When you need more – more productivity, more economy, more simplicity, more comfort – unleash your Puma CVX. A highly productive and versatile tractor that is easy to use and delivers everything you need to handle your daily tasks such as snow clearing and gritting in the harshest winter conditions, heavy duty road maintenance, demanding bio-composting applications or transporting heavy or abnormal loads: with 8 models ranging from 131 to 228hp, Puma CVX gives you more.

THE ULTIMATE PERFORMANCE EFFICIENCY

Automatic Productivity Management (APM) coordinates the engine, transmission and PTO with the Multicontroller and travel pedal to give you the perfect balance of fuel efficiency and power, adjusting the engine to the lowest possible speed to save fuel and increase productivity. Puma CVX optimizes fuel efficiency and performance, so you can focus on the task in hand.

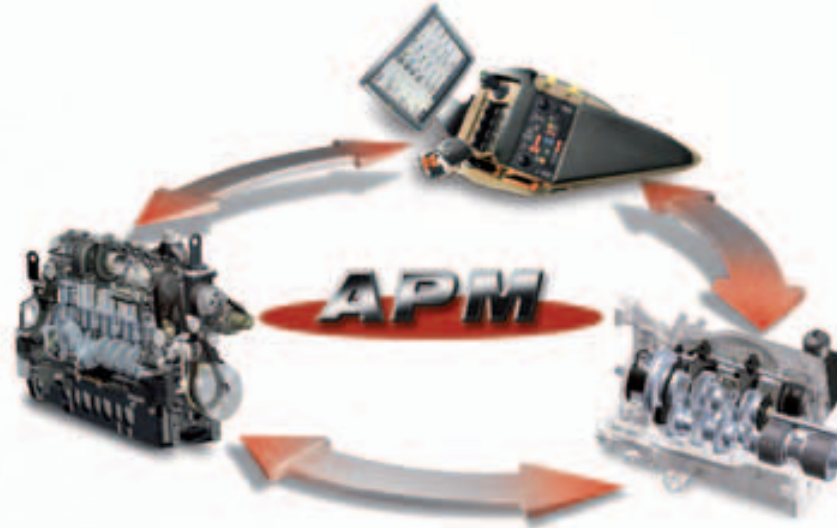

MODEL	PUMA CVX 130	PUMA CVX 145	PUMA CVX 160	PUMA CVX 170
Number of cylinders / capacity (cm ³)	6/6,728	6/6,728	6/6,728	6/6,728
Rated engine power ECE R120 ¹⁾ (kW/hp)	96/131	107/146	118/160	123/167
Min. length / width / height (mm) ²⁾	4,719 / 2,470 / 3,070	4,719 / 2,470 / 3,070	4,719 / 2,470 / 3,070	5,017 / 2,682 / 3,090
MODEL	PUMA CVX 185	PUMA CVX 200	PUMA CVX 215	PUMA CVX 230
Number of cylinders / capacity (cm ³)	6/6,728	6/6,728	6/6,728	6/6,728
Rated engine power ECE R120 ¹⁾ (kW/hp)	136/185	147/200	158/215	167/228
Min. length / width / height (mm) ²⁾	5,017 / 2,682 / 3,090	5,017 / 2,682 / 3,090	5,017 / 2,682 / 3,090	5,017 / 2,682 / 3,090

¹⁾ ECE R120 correspond to ISO 14396 and 97/68/EC

²⁾ All dimensions related to standard tyres



IN FULL CONTROL

The cab of the Puma CVX is a perfectly designed command and control centre in which large power reserves can be tapped precisely and comfortably at the touch of a finger. Monitors, regulators, controls and the Multicontroller are in full view and easy reach of the driver to guarantee full control of the machine and equipment at all times. In this cab the driver not only feels safe, but also supremely comfortable.

ERGONOMICALLY POSITIONED CONTROLS

The newest Multicontroller is operator friendly and integrated into the adjustable right-hand armrest of the driver's seat, putting six of the tractor's key functions within easy reach. The Intuitive Control Panel multifunction keypad is also integrated into the right-hand armrest and provides easy control of all the tractor's important functions such as the hydraulic system, PTO(s), 4WD and differential lock, and headland management. The tractor monitor and performance monitor are integrated into the right-hand A-pillar within the driver's natural field of vision to provide the most important performance information at a glance.



The AFS Pro 700™ monitor screen is integrated into the armrest to provide performance monitoring, vehicle settings, video inputs and simultaneous command and control of ISOBUS-compatible machinery.

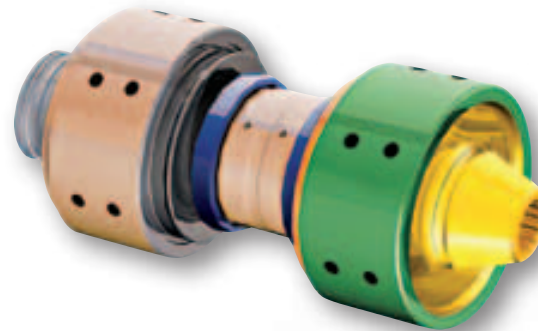

Case IH was the first manufacturer in the world to introduce DKT™ Double Clutch Technology. This stepless transmission - a unique feature of the Puma tractor range - optimises transmission efficiency. With DKT, you will enjoy a truly smooth ride together with best-in-class fuel and power efficiency.



BIG ON POWER, BIG ON RETURNS

MAGNUM SERIES



SMOOTH POWER AND FUEL ECONOMY

With 5 models ranging from 235 to 340hp, the Magnum gives you the power, durability, comfort and productivity you need for your heavy transport work or on the construction site. It delivers the power required to get through the toughest conditions and achieve a performance without equal. It is designed to maximise uptime so you can rely on consistently high productivity in all conditions, and it offers a premium operator environment to help you through it. The Magnum range brings reliable technology and value to your business.

DESIGNED AS YOU WANTED IT

Producers told us what they wanted from the operator interface of their Magnum tractors and we designed the new Multicontroller armrest console accordingly: it puts all key functions at your fingertips and offers the largest touch screen in the industry, the AFS Pro 700, which can even be customised to display the information most important to you.

SMOOTH FUEL ECONOMY

Throughout the new line-up of the Magnum range, improved fuel consumption reduces fuel inputs by up to 15%. The Case IH Efficient Power technology benefits the owner and the environment as it improves horsepower, engine responsiveness, fuel economy and engine reliability, whilst lowering emissions. In addition, running with minimal down time, extended service intervals with easy and effective routine servicing means more savings can be achieved through years of improved productivity.

SOLID EFFICIENCY

For raw pulling efficiency, it's tough to beat the proven Magnum Full-Powershift transmission with its integrated automatic shift. It provides seamless smooth shifting from start to 40 or 50kph. For slow-speed special applications, an optional shift through creeper transmission with 5 forward and 2 reverse speeds is available on all models.



MODEL	MAGNUM 235	MAGNUM 260	MAGNUM 290	MAGNUM 315	MAGNUM 340
Number of cylinders / capacity (cm ³)	6/8,700	6/8,700	6/8,700	6/8,700	6/8,700
Rated engine power ECE R120 ¹⁾ (kW/hp)	173/235	189/257	209/284	229/311	250/340
Min. length / width / height (mm) ²⁾	6,428 / 2,550 / 3,378	6,428 / 2,550 / 3,378	6,428 / 2,550 / 3,378	6,428 / 2,550 / 3,378	6,428 / 2,550 / 3,378

¹⁾ ECE R120 correspond to ISO 14396 and 97/68/EC

²⁾ All dimensions related to standard tyres

EFFICIENT POWER

To be successful you need powerful equipment that is easy to use, even when performing in tough conditions and short time frames, technologies that minimize your fuel and operating costs, and advice from people who know your fields as well as they know their equipment. In short, you need Case IH Efficient Power, because you only get one shot at any season. Case IH offers powerful, smart, simple equipment with unmatched customer support and people who work alongside you in the field to help you be ready for the opportunities and challenges of your daily business.

PRODUCTIVITY

Case IH launches the Efficient Power range based on SCR AdBlue technology to meet the dramatic reduction in emissions demanded by the European Union for 2014. With SCR AdBlue, Case IH is using fully-developed technology - proven in more than a million machines. The no-compromise engineering of the new Efficient Power engines delivers a real upgrade in fuel efficiency and power compared to Tier 3a-compliant tractors.

EASY OPERATION

Automatic Productivity Management (APM) concentrates on optimising efficiency while you concentrate on your work. The Multicontroller, created together with people who use tractors day in, day out, enables you to operate all key functions with one finger. Intuitive control panel and AFS Pro touch screens put all important functions at your fingertips.

COST EFFECTIVENESS

Sometimes the best way to make a profit is to make sure you're not spending more than you need to. The high-horsepower diesel engines from Case IH burn on average 10 percent less fuel than comparable Tier 3 machines. In addition routine service intervals have been lengthened to save time and money. All pretty powerful arguments to look at some new equipment.

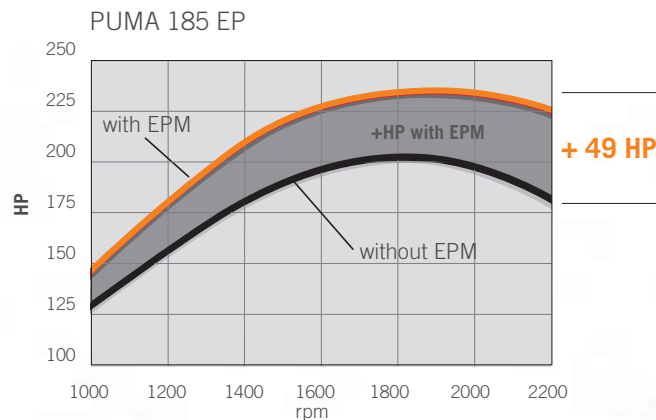
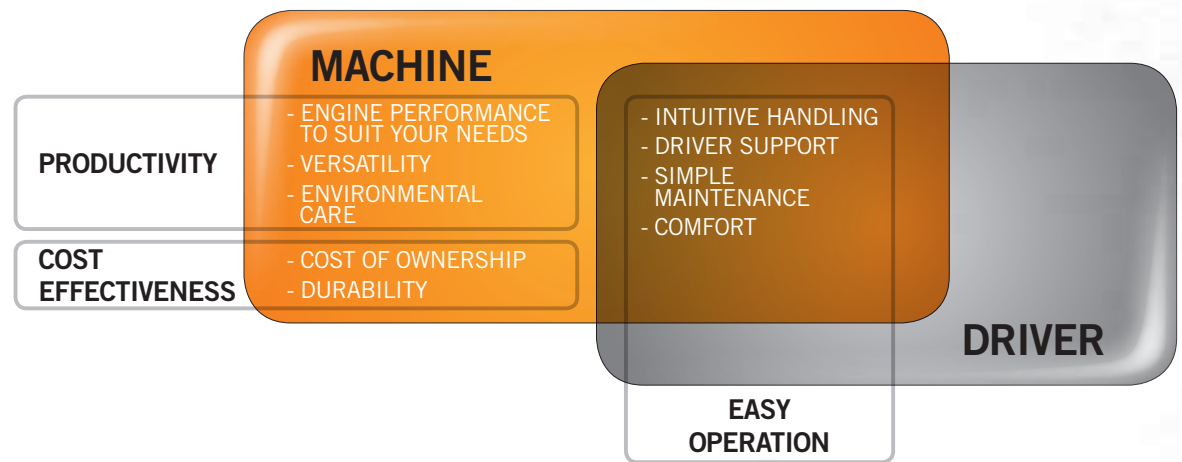

POWER GROWTH

10 percent extra performance becomes available simply by throttling back to 1900 engine revs. For your Puma 185 EP, this means a power increase of 18 hp in any application.

ACTIVE ENGINE POWER MANAGEMENT

The Case IH Engine Power Management (EPM) actively delivers up to 15 percent additional power boost. This extra performance becomes available automatically according to the demand in road transport and PTO applications. For your Puma 185 EP, this means a further power increase of 31 hp.

TAILOR-MADE ALL-ROUND SOLUTIONS FOR WORKING IN ALL SEASONS

There is only one single-source supplier with this level of expertise: in close cooperation with the equipment manufacturers, Case IH provides you with ideal tailor-made solutions for working all year round. Snow clearing, street cleaning, care of green spaces, sports grounds and parks, and construction applications – everything can be accomplished efficiently and economically with a Case IH tractor.

GET THE BEST OUT OF FRONT-MOUNTED EQUIPMENT – WITH THE INTEGRATED CASE IH MUNICIPALITY FRAME

With the new frame you are ideally equipped for heavy duty tasks. Its superiority is derived from its improved design concept and tremendous stability. Implements with widely extended booms and high torsional forces can be operated effortlessly and safely. A quick-hitch plate reduces the time needed to mount a wide variety of municipal implements. In combination with the quick-hitch DIN plate, you can convert quickly and easily to a front hydraulic system. This makes it possible to mount and operate front implements on a three-point linkage.



OUTSTANDING LOADER PERFORMANCE

The Case IH LRZ front loaders combine power, rigidity, loading performance and modern design to form an innovative loader concept. These loaders excel in functionality and feature technically intelligent solutions to give you pleasure in your daily work by delivering high performance and comfortable handling.



SPECIAL SOLUTIONS

Your Case IH partner offers special solutions for your working requirements such as integrated reverse drive and a protection system for working in rough terrain.



SAFETY FIRST

Enabling you and your staff to work safely is a clear objective of Case IH engineers. In addition to FOPS and ROPS requirements, they consider all kinds of safety equipment including working lights, beacon lights and warning signs. Your dealer will equip your Case IH tractors so they are 'tailor-made' to match your requirements.



NOKIAN TRI 2

Special tyres for municipal applications. Versatile and rugged for long service life. Superior grip, great load-bearing characteristics and a pleasing car-like driving "feel". Subject to speed class (max. 65kph) this tyre is ideally suited to on-road use. Reduced rolling resistance and fuel consumption.



NOKIAN FORESTRY TYRES

Special tyres for versatile forestry applications. Enhanced operational capabilities thanks to a special rubber mixture designed specifically for forestry applications, and a robust diagonal type of construction. Good self-cleaning in tread pattern.



TRELLEBORG T404

Special tyres for working on grassed areas. Tyres with a wide "footprint" to reduce ground compression.

SERVICEABILITY

Keep driving! Daily checks and cleaning have been made easier with the new swing-out radiator package, while the air filter is conveniently located for quick inspection. In addition it's simple to check the oil level, with no need to open the engine hood.

When you buy a Case IH machine you can be sure not only that you're buying the best product, but also that you've got the best dealer back-up. Case IH dealers can offer advice on selecting and financing the right machine, they ensure delivery of what you need when you need it, and then continue to support you and your equipment with the service and spare parts backing you'd expect from a name as trusted as Case IH.



ALL THE PARTS AND SERVICE TO KEEP YOUR EQUIPMENT RUNNING

Find the full line of Case IH parts and components at your local dealer. Plus full service maintenance programmes and industry-leading warranties. It's expertise applied by skilled, factory-trained service professionals committed to providing you maximum uptime, season after season.



AROUND THE CLOCK. AROUND THE COUNTRY

Case IH Max Service is a customer support service that provides 24-hour, seven-day-a-week access to the people, products, and parts support needed to keep your operation running during the times most critical to your profitability. Max Service backs up your dealer with every resource available to Case IH, to help maximize uptime and productivity of Case IH equipment and increase your return on investment through access to product experts and 24/7 Emergency Breakdown Assistance.



OFFERING FINANCING SOLUTIONS FOR MORE THAN 50 YEARS

CNH Capital's extensive experience in the agricultural industry has created a deep understanding of your unique needs. Competitive equipment financing with flexible payments can reduce upfront payments with operating and finance leases. For other needs choose from credit cards specific to the agricultural industry. We can even help you finance crop-input products or land rental. There are financing options that fit the way you farm. CNH Capital helps you find them.

**VISIT OUR FANSHOP AT
WWW.CASEIHSHP.COM**



MODEL	QUANTUM 65V	QUANTUM 75V	QUANTUM 85V	QUANTUM 95V	QUANTUM 105V	QUANTUM 75N	QUANTUM 85N	QUANTUM 95N	QUANTUM 105N	QUANTUM 75F	QUANTUM 85F	QUANTUM 95F	QUANTUM 105F
ENGINE													
Cylinders/capacity (cm ³)	4/3,200/Turbocharged, intercooled			4/4,500/ Turbocharged, intercooled		4/3,200/Turbocharged, intercooled		4/4,500/Turbocharged, intercooled		4/3,200/Turbocharged, intercooled		4/4,500/Turbocharged, intercooled	
Rated engine power ECE R120 ¹⁾ @ rpm (kW/hp)	48/65	57/78	65/88	71/97	78/106	57/78	65/88	71/97	78/106	57/78	65/88	71/97	78/106
Max. torque ECE R120 ¹⁾ (Nm @ engine rpm)	290 @ 1,250	330 @ 1,250	352 @ 1,250	398 @ 1,300	425 @ 1,300	330 @ 1,250	352 @ 1,250	398 @ 1,300	425 @ 1,300	330 @ 1,250	352 @ 1,250	398 @ 1,300	425 @ 1,300
TRANSMISSION*													
16x16 Synchroshift / 32x16 Synchroshift with mechan. Splitter							●/○						
16x16 Synchroshift with Powershuttle / 32x16 2-speed Powershift with Powershuttle							○/○						
28x16 Synchroshift with Powershuttle and creeper / 44x16 2-speed Powershift with Powershuttle and creeper							○/○						
PTO													
Type	Electro-hydraulic engagement												
Rear PTO speeds (rpm)	540/540E 48l/min or 1,000 + proportional ground speed												
HYDRAULIC SYSTEM													
Control type	MHC (Mechanical Hitch Control) or EHC (Electronic Hitch Control)												
Max. pump flow	48l/min (64l/min with high flow pump)												
Lift capacity @ 610mm (kg)	2,600												
DIMENSIONS AND WEIGHT²⁾													
Min. length / width / height (mm)	3,692 / 1,080 / 2,145		3,779 / 1,200 / 2,190			3,692 / 1,305 / 2,235		3,779 / 1,530 / 2,250		3,682 / 1,398 / 2,273		3,769 / 1,398 / 2,273	
Min. weight (kg)	2,710		2,790			2,765		2,855		2,910		3,000	
Wheelbase (mm)	2,093		2,180			2,093		2,180		2,093		2,180	
TYRES*													
Tyres	front: 240/70R16, rear: 320/85R24									front: 260/70R20, rear: 380/70R28			

MODEL	FARMALL 55 C	FARMALL 65 C	FARMALL 75 C	FARMALL 85 C	FARMALL 95 C	FARMALL 105 C
ENGINE						
Cylinders/capacity (cm ³)	4/3,200 /Turbocharged, intercooled			4/3,400 /Turbocharged, intercooled		
Rated engine power ECE R120 ¹⁾ @ 2,300 rpm (kW/hp)	41/56	48/65	55/75	63/86	73/99	79/107
Max. torque ECE R120 ¹⁾ @ 1,500 rpm (Nm)	221	260	310	351	407	444
TRANSMISSION*						
12x12 Synchroshift	●	●	●	●	●	●
12x12 Synchroshift with Powershut	○	○	○	○	○	○
24x24 2-speed Powershift with Powershuttle	-	-	-	○	○	○
20x12 Synchroshift with creeper	-	-	-	○	○	○
20x20 Synchroshift with creeper	○	○	○	-	-	-
20x20 Synchroshift with Powershuttle and creeper	○	○	○	-	-	-
PTO						
Type	Electro-hydraulic engagement					
Rear PTO speeds (rpm)	540 or 540/1,000 or 540/540E/1,000 + proportional ground speed					
HYDRAULIC SYSTEM						
Control type	MHC (Mechanical Hitch Control)			MHC (Mechanical Hitch Control) or EHC (Electronic Hitch Control)		
Max. pump flow	48l/min			48l/min (optional 64l/min combined flow system)		
Lift capacity @ 610mm standard/optional (kg)	1,800/2,100			2,100/3,200		
DIMENSIONS AND WEIGHT²⁾						
Min. length / width / height (mm)	3,789 / 1,922 / 2,420			4,247 / 1,923 / 2,610		
Min. weight (kg)				3,700		
Wheelbase (mm)				2,258		
TYRES*						
Municipal Tyres: Nokian Tri 2	front: 360/80R20, rear: 440/80R30					

● Standard Equipment

○ Optional Equipment

¹⁾ ECE R120 correspond to ISO 14396 and 97/68/EC

²⁾ All dimensions related to standard tyres

³⁾ depends on market specifications

MODEL	FARMALL 95 U	FARMALL 105 U	FARMALL 115 U
ENGINE			
Cylinders/capacity (cm ³)		4/3,400/Turbocharged, intercooled	
Rated engine power ECE R120 ¹⁾ @ 2,300 rpm (kW/hp)	73/99	79/107	84/114
Max. torque ECE R120 ¹⁾ @ 1,500 rpm (Nm)	407	444	461
TRANSMISSION*			
12x12 Synchroshift with Powershuttle	●	●	●
24x24 2-speed Powershift with Powershuttle	○	○	○
20x20 Synchroshift with Powershuttle and creeper	○	○	○
PTO			
Type		Electro-hydraulic engagement	
Rear PTO speeds (rpm)		540/1000 (less ground speed)	
HYDRAULIC SYSTEM			
Control type		EHC (Electronic Hitch Control)	
Max. pump flow		65l/min (optional 84l/min)	
Lift capacity @ 610mm standard/optional (kg)		3,190/4,770	
DIMENSIONS AND WEIGHT²⁾			
Min. length / width / height (mm)		4,161 / 2,100 / 2,673	
Min. weight (kg)		4,150	
Wheelbase (mm)		2,420	
TYRES*			
Municipal Tyres: Nokian Tri 2		front: 400/80 R24, rear: 480/80 R34	

MODEL	FARMALL 95 U PRO	FARMALL 105 U PRO	FARMALL 115 U PRO
ENGINE			
Cylinders/capacity (cm ³)		4/3,400/Turbocharged, intercooled	
Rated engine power ECE R120 ¹⁾ @ 2,200 rpm (kW/hp)	73/99	79/107	84/114
Max. torque ECE R120 ¹⁾ @ 1,500 rpm (Nm)	407	444	461
TRANSMISSION*			
32x32 Semi Powershift with Powershuttle		●	
PTO			
Type		Electro-hydraulic engagement	
Rear PTO speeds (rpm)		540/540E/1,000/1,000E with stationary ground speed	
HYDRAULIC SYSTEM			
Control type		EHC (Electronic Hitch Control)	
Max. pump flow		60l/min OCLS/optional 100l/min CCLS	
Lift capacity @ 610mm standard/optional (kg)		4,100/4,700	
DIMENSIONS AND WEIGHT²⁾			
Min. length / width / height (mm)		4,166 / 2,100 / 2,673	
Min. weight (kg)		4,500	
Wheelbase (mm)		2,420	
TYRES*			
Municipal Tyres: Nokian Tri 2		front: 460/65R24, rear:480/80R34	

● Standard Equipment

○ Optional Equipment

¹⁾ ECE R120 correspond to ISO 14396 and 97/68/EC

²⁾ All dimensions related to standard tyres

³⁾ depends on market specifications

MODEL	MAXXUM 110	MAXXUM 120	MAXXUM 130	MAXXUM 115	MAXXUM 125	MAXXUM 140
ENGINE						
Cylinders/capacity (cm ³)	4/4,485/Turbocharged, intercooled			6/6,728/Turbocharged, intercooled		
Rated engine power ECE R120 ¹⁾ @ 2,200 rpm (kW/hp)	81/110	89/121	96/131	85/116	92/125	103/140
Max. engine power ECE R120 ¹⁾ @ 1,800-1,900 rpm - Power Management (kW/hp)	89/121	98/133	105/143	93/126	101/137	113/15
Max. torque ECE R120 ¹⁾ @ 1,500 rpm (Nm)	498	549	590	522	566	632
TRANSMISSION*						
24x24 2-speed Powershift with Powershuttle	●					
48x48 2-speed Powershift with Powershuttle and creeper	○					
16x16 Semi Powershift with Powershuttle	○					
32x32 Semi Powershift with Powershuttle and creeper	○					
PTO						
Type	Electro-hydraulic shiftable with progressive PTO control					
Rear PTO speeds (rpm)	540/540E/1,000		540/540E/1,000 or 540E/1,000/1,000E	540/540E/1,000		540/540E/1,000 or 540E/1,000/1,000E
HYDRAULIC SYSTEM						
Control type	EHC (Electronic Hitch Control) with hitch ride control					
Max. pump flow	80l/min fixed displacemet or 113l/min wih pressure & flow compensation/load sensing					
Max. lift capacity 80/113l pump (kg)	7,115/7,864					
DIMENSIONS AND WEIGHT²⁾						
Min. length / width / height (mm)	4,292 / 2,205 / min. height 2,758 low roof; 2,878 high roof			4,532 / 2,205 / min. height 2,758 low roof; 2,878 high roof		
Min. weight (kg)	4,890			5,010		5,020
Wheelbase standard / suspended front axle (mm)	2,387/2,439			2,627/2,679		
TYRES*						
Municipal Tyres: Nokian Tri 2	front: 440/80R24, rear: 480/80R38					

MODEL	MAXXUM 110 MC	MAXXUM 120 MC	MAXXUM 130 MC	MAXXUM 115 MC	MAXXUM 125 MC	MAXXUM 140 MC
ENGINE						
Cylinders/capacity (cm ³)	4/4,485/Turbocharged, intercooled			6/6,728/Turbocharged, intercooled		
Rated engine power ECE R-120 ¹⁾ @ 2,200 rpm (kW/hp)	81/110	89/121	96/131	85/116	92/125	103/140
Max. engine power ECE R-120 ¹⁾ @ 1,800-1,900 rpm - Power Management (kW/hp)	89/121	98/133	105/143	93/126	101/137	113/15
Max. torque ECE R-120 ¹⁾ @ 1,500 rpm (Nm)	498	549	590	522	566	632
TRANSMISSION*						
16x16 Semi Powershift with Powershuttle	●					
32x32 Semi Powershift with Powershuttle and creeper	○					
17x16 Semi Powershift Economy 40 kph with Powershuttle	○					
PTO						
Type	Electro-hydraulic shiftable with progressive PTO control					
Rear PTO speeds (rpm)	540/540E/1,000		540/540E/1,000 or 540E/1,000/1,000E	540/540E/1,000		540/540E/1,000 or 540E/1,000/1,000E
HYDRAULIC SYSTEM						
Control type	EHC (Electronic Hitch Control) with hitch ride control					
Max. pump flow	113l/min with pressure flow compensation / sensing					
Max. lift capacity (kg)	7,864					
DIMENSIONS AND WEIGHT²⁾						
Min. length / width / height (mm)	4,292 / 2,205 / min. height 2,758 low roof; 2,878 high roof			4,532 / 2,205 / min. height 2,758 low roof; 2,878 high roof		
Min. weight (kg)	4,890			5,010		5,020
Wheelbase standard/suspended front axle (mm)	2,387/2,439			2,627/2,679		
TYRES*						
Municipal Tyres: Nokian Tri 2	front: 440/80R24, rear: 480/80R38					

● Standard Equipment

○ Optional Equipment

¹⁾ ECE R120 correspond to ISO 14396 and 97/68/EC

²⁾ All dimensions related to standard tyres

³⁾ depends on market specifications

MODEL	PUMA 130	PUMA 145	PUMA 160	PUMA 170	PUMA 185	PUMA 200	PUMA 215
ENGINE							
Cylinders/capacity (cm ³)	6/6,728/Turbocharged, intercooled						
Rated engine power ECE R120 ¹⁾ @ 2,200 rpm (kW/hp)	96/131	107/146	118/160	123/167	136/185	147/200	158/215
Max. engine power ECE R120 ¹⁾ - Power Management (kW/hp @ engine rpm)	126 / 171 @ 1,800-1,900	138 / 188 @ 1,800-1,900	149 / 203 @ 1,800-1,900	160 / 218 @ 1,900-2,000	172 / 234 @ 1,900-2,000	184 / 250 @ 1,900-2,000	191 / 260 @ 1,900-2,000
Max. torque ECE R120 ¹⁾ @ 1,500 rpm (Nm)	633	700	766	825	862	927	995
TRANSMISSION*							
18x6 Semi/Full Powershift with Powershuttle	-	○/●	○/●	-/●	-/●	-/●	-/●
19x6 Semi/Full Powershift Economy 40 kph with Powershuttle	-	○/○	○/○	-/○	-/○	-/○	-/○
19x6 Semi/Full Powershift 50 kph with Powershuttle	●/○	○/○	○/○	-/○	-/○	-/○	-/○
PTO							
Type	Electro-hydraulic shifttable with progressive PTO control						
Rear PTO speeds (rpm)	540/540E/1,000 or 540E/1,000/1,000E			540E/1,000 or 1,000/1,000E or 540/1,000/1,000E			
HYDRAULIC SYSTEM							
Control type	EHC (Electronic Hitch Control) with hitch ride control						
Max. pump flow standard/optional	113/min PFC/-			120/min / 150/min PFC			
Max. lift capacity (kg)	8,257			10,460			
DIMENSIONS AND WEIGHT²⁾							
Min. length / width / height (mm)	4,719 / 2,470 / 3,070			5,017 / 2,682 / 3,090			
Min. weight (kg)	5,750		5,950		7,300		
Wheelbase (mm)	2,789			2,884			
TYRES*							
Municipal Tyres: Nokian Tri 2	front: 440/80R28, rear: 540/80R38						

MODEL	PUMA CVX 130	PUMA CVX 145	PUMA CVX 160	PUMA CVX 170	PUMA CVX 185	PUMA CVX 200	PUMA CVX 215	PUMA CVX 230
ENGINE								
Cylinders/capacity (cm ³)	6/6,728/Turbocharged, intercooled							
Rated engine power ECE R120 ¹⁾ @ 2,200 rpm (kW/hp)	96/131	107/146	118/160	123/167	136/185	147/200	158/215	167/228
Max. engine power ECE R120 ¹⁾ - Power Management (kW/hp @ engine rpm)	126 / 171 @ 1,800-1,900	138 / 188 @ 1,800-1,900	149 / 203 @ 1,800-1,900	160 / 218 @ 1,900-2,000	172 / 234 @ 1,900-2,000	184 / 250 @ 1,900-2,000	191 / 260 @ 1,900-2,000	198 / 269 @ 1,800
Max. torque ECE R120 ¹⁾ @ 1,500 rpm (Nm)	631	698	767	825	862	927	995	1089
TRANSMISSION*								
Continuously variable transmission 0-40 (50) kph	●							
PTO								
Type	Electro-hydraulic shifttable with progressive PTO control							
Rear PTO speeds (rpm)	540/540E/1,000 or 540E/1,000/1,000E				540E/1,000 or 1,000/1,000E or 540/1,000/1,000E			
HYDRAULIC SYSTEM								
Control type	EHC (Electronic Hitch Control) with dynamic oscillation cancellation ride control							
Max. pump flow	125/min / 140/min PFC				150/min / 170/min PFC			
Max. lift capacity (kg)	8,257				10,460			
DIMENSIONS AND WEIGHT²⁾								
Min. length / width / height (mm)	4,719 / 2,470 / 3,070				5,017 / 2,682 / 3,090			
Min. weight (kg)	5,800		6,000		7,300			
Wheelbase (mm)	2,789			2,884				
TYRES*								
Municipal Tyres: Nokian Tri 2	front: 440/80 R28, rear: 540/80 R38				front: 540/65 R30, rear: 650/65 R42			

● Standard Equipment

○ Optional Equipment

¹⁾ ECE R120 correspond to ISO 14396 and 97/68/EC

²⁾ All dimensions related to standard tyres

³⁾ depends on market specifications

MODEL	MAGNUM 235	MAGNUM 260	MAGNUM 290	MAGNUM 315	MAGNUM 340
ENGINE					
Cylinders/capacity (cm ³)	6/8,700/Turbocharged, intercooled				
Rated engine power ECE R120 ¹⁾ @ 2,000 rpm (kW/hp)	173/235	189/257	209/284	229/311	250/340
Max. engine power ECE R120 ¹⁾ @ 1,800 rpm - Power Management (kW/hp)	201/273	219/298	241/328	263/358	286/389
Max. torque ECE R120 ¹⁾ @ 1,400 rpm (Nm)	1,157	1,267	1,397	1,531	1,671
TRANSMISSION*					
19x4 Full Powershift and Powershuttle	●				
23x6 Full Powershift and Powershuttle	○				
PTO					
Type	Electro-hydraulic with Auto PTO control				
Rear PTO speeds (rpm)	1,000 or 540/1,000				
HYDRAULIC SYSTEM					
Control type	Electronic Hitch Control (EHC) with hitch ride control				
Max. pump flow standard/high flow/twin flow (l/min)	161/225/282				
Max. lift capacity (kg)	7,424	8,573		8,573	
DIMENSIONS AND WEIGHT²⁾					
Min. length / width / height (mm)	6,428 / 2,550 / 3,378				
Min. weight (kg)	9,136		9,377		9,568
Wheelbase (mm)	3,055				
TYRES*					
Tyres	front: 600/70R30, rear: 710/70R42				

● Standard Equipment

○ Optional Equipment

¹⁾ ECE R120 correspond to ISO 14396 and 97/68/EC

²⁾ All dimensions related to standard tyres

³⁾ depends on market specifications

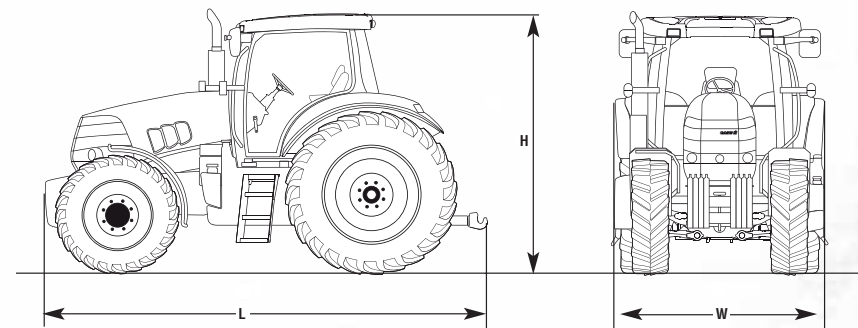

! Safety never hurts! Always read the Operator's Manual before working with any equipment. Inspect equipment before using it, and be sure it is operating Properly. Follow the Product safety signs, and use any safety features Provided. This literature has been published for worldwide circulation. The standard and optional equipment and the availability of individual models may vary from one country to the next. Case IH reserves the right to undertake modifications without prior notice to the design and technical equipment at all times without this resulting in any obligation whatsoever to make such modifications to units already sold. Whilst every effort is made to ensure that the specifications, descriptions and illustrations in this brochure are correct at the time of going to press, these are also subject to change without prior notice. Illustrations may show optional equipment or may not show all standard equipment. Case IH recommends **AKCELA** lubricants.

CNH UK Ltd., Cranes Farm Road, Basildon, Essex SS14 3AD

© 2013 CASE IH - Municipal-COM-BR - Free phone 00800 22 73 44 00 - Printed in Italy - 01/13 - TP01 - Cod. 12C8002/COM



www.caseih.com